

Technical Manual

Generic Vender – Service Manual Only



**Models DNCB 640, DNCB 448
Beginning Production Run 5732DK**

Manufactured by

CRANE[®] MERCHANDISING SYSTEMS

Crane Merchandising Systems
P.O. Drawer 719
Williston, SC 29853-0719
803-266-5001
fax: 803-266-5049
Visit us on the web: www.cranems.com

English Manual Part #####

Service Only

Table of Contents

GENERAL INFORMATION

Application	3
Vender Safety Precautions	3
Product Identification	3
Physical Characteristics	3
Receiving Inspection	3

A INSTALLATION & SETUP

Unpacking the Vender	3-4
Electric Power Requirements	4
Power Supply and Grounding Requirements	4-5
Placing the Vender on Location	5
Level the Vender	6
Space the Vender	6
Coin Changers and Other Accessories	7
Setting the Temperature Control	7
Loading the Change Tubes	7
Loading Product	7
Initial Loading	7

B PROGRAMMING

Normal/Service Mode	8
Historical Data	9
Interval Data – Resettable Data	9
Set Price	9
Cash Settings	9-10
User Menu	11-20
Diagnostics Menu	20-21
Quick Reference Prompts	22
Default Space-To-Sales Setting	23
Set Vender Type	24

C GENERAL MAINTENANCE

Power	25
Cleaning	25
Refrigeration Condenser	25
Coin Acceptor	25
Lubricating the Vender	25
EPROM Replacement	26 - 27

D MAJOR COMPONENT DESCRIPTION

Refrigeration	28
Vend Motor Operation	28
SBC Control Board	29

E TROUBLESHOOTING FLOWCHARTS

All Coins are Rejected	30
All Bills are Rejected	31
Incorrect Change Dispensed	32
Selection Will Not Vend	33
Ice / Frost on Evaporator	34
Compressor Runs Continuously	34
Compressor Will Not Start	35
Machine Not Cooling	36
Can't Enter the Menu or Diagnostics	37
Lights Are Not On	38
One or More Motors Run When Main Door is Closed	39
Sold Out	40
The Display is Dead	41
Can't Read the Display	42

Table of Contents

F	WIRING DIAGRAMS AND SCHEMATICS	
	Figure 1 – Domestic DN448 Wiring Diagram	43 – 44
	Figure 1 – Export DN448 Wiring Diagram	45 – 46
	Figure 1 – Domestic DN640 Wiring Diagram	47 – 48
	Figure 1 – Export DN640 Wiring Diagram	49 – 50
	Figure 2 – Compressor Wiring Diagram.....	51
G	PARTS LIST	52 – 88
	Main Door Exterior	53 - 56
	Main Door Interior (A)	57 – 59
	Main Door Interior (B)	60
	Select Panel	61 – 62
	LED Lighting	63 – 64
	Electronic Components	65 – 66
	Inner Door	67 – 68
	Harnessing	69 - 70
	Power Distribution Panel	71 - 72
	Cabinet and Vend Mechanism (Section 1)	73 – 75
	Miscellaneous Labels	76
	Cabinet and Vend Mechanism (Section 2)	77 - 78
	Can/Bottle Chute Assembly	79 – 80
	Evaporator Fan Assembly.....	81 - 82
	Refrigeration System	83 - 84
	Screws	85 - 86
	Washers, Bolts, & Miscellaneous Hardware.....	87 - 88

Special Note: Crane Merchandising Systems Dixie-Narco part numbering has changed. Many of the 11 digit numbers are now 8 digit numbers. The last 3 digits were dropped in the new numbering system. An example of this is 800,102,970.01 is now 80010297.



High Voltage Warning / Electrical Warning
Danger electricity, electric shock.



A Generic Warning.



Hazard Warning: Beware of moving machinery –
Entanglement hazard. Keep hands, loose clothing,
and long hair away from moving parts.

APPLICATION

This information applies to DNCB640 & DNCB448 venders manufactured the fourth quarter 2012 which have significant differences in programming and parts content from previous venders. To order parts or information pertaining to this vender, please contact Crane Merchandising Systems.

The second alpha-character identifies the year:

- K = 2012
- L = 2013
- M = 2014
- N = 2015
- O = 2016

VENDER SAFETY PRECAUTIONS

Please read this manual in its entirety. This service information is intended for use by a qualified service technician, who is familiar with proper and safe procedures to be followed when repairing, replacing, or adjusting any Crane Merchandising Systems vender components. All repairs should be performed by a qualified service technician who is equipped with the proper tools and replacement components, using genuine Crane Merchandising Systems factory parts.

REPAIRS AND/OR SERVICING ATTEMPTED BY UNINFORMED PERSONS CAN RESULT IN HAZARDS DEVELOPING DUE TO IMPROPER ASSEMBLY OR ADJUSTMENTS WHILE PERFORMING SUCH REPAIRS. PERSONS NOT HAVING A PROPER BACKGROUND MAY SUBJECT THEMSELVES TO THE RISK OF INJURY OR ELECTRICAL SHOCK WHICH CAN BE SERIOUS OR EVEN FATAL.



CE Mark & IIA Declaration:

An updated CE Mark or IIA Declaration document can be provided upon request. If needed please contact Technical Support Manager in Williston, SC. Phone: 1-803-266-5001 or Email: bstaub@cranems.com.

PHYSICAL CHARACTERISTICS

	DNCB640 (Wide)	DNCB448 (Narrow)
HEIGHT	72"	72"
WIDTH	37"	28"
DEPTH	36"	36"
SHIPPING WEIGHT	833 lbs.	678 lbs.
LOADED WEIGHT 4 DEEP 12OZ CANS	TBD lbs	TBD lbs

Model	Number of Selections	Number of Narrow Columns
DNCB640	10	10
DNCB640	9	10
DNCB448	7	7

PRODUCT IDENTIFICATION

First production of DNCB640 & DNCB448 was Fourth quarter of 2012. The production date of Crane Merchandising Systems products is determined by the date code incorporated in the serial number.

The vender serial number takes the form yyyyzz-xxxx. The last 4 digits (xxxx) identify the specific vender. The first 4 digits (yyyy) identify the manufacturing run that the vender was built in. The two alpha characters (zz) identify the quarter and the year the vender was built. The first alpha-character identifies the quarter.

- A = 1st quarter
- B = 2nd quarter
- C = 3rd quarter
- D = 4th quarter

RECEIVING INSPECTION

Upon receipt, inspect the vender for any shipping damage. If there is any damage have the driver note the damage on the bill of lading and notify Crane Merchandising Systems. Although the terms of sale are FOB shipping point, which requires the consignee to originate shipping damage claims, Crane Merchandising Systems will gladly help if you must file a claim.

UNPACKING THE VENDERS

Remove the stretch wrap and top cover from the vender. Product cards are installed in the select buttons.



DO NOT STORE THE VENDER OUTSIDE WITH THE STRETCH WRAP ON. THIS COULD CAUSE THE STRETCH WRAP TO BOND TO THE VENDER'S SURFACE, WHICH COULD DAMAGE THE FINISH.

Remove the shipping boards from the bottom of the vender. The shipping boards are attached by the leveling legs. To avoid unnecessary damage to the leveling legs or base, remove the shipping boards by using a 1½” or 38mm socket type wrench to unscrew the leveling legs. Be sure to replace the legs after removing the shipping boards.

Once the vender is unpacked, check the columns in the stack for any additional parts, price/product labels, service/operation manual or other information concerning factory-equipped accessories such as coin mechanism and validator.

WARNING

TO AVOID THE POSSIBILITY OF A FIRE HAZARD, DO NOT STORE ANYTHING OR ALLOW DEBRIS OF ANY KIND TO ACCUMULATE IN THE BOTTOM OF THE DOOR, IN AND AROUND THE REFRIGERATION COMPARTMENT OF THE CABINET, OR IN FRONT OF THE EVAPORATOR AND CONDENSER COILS.



WARNING: ENSURE THAT POWER IS DISCONNECTED FROM THE VENDER OR THAT THE POWER INTERRUPT SWITCH IS NOT DEFEATED BEFORE INSPECTING OR REPLACING THE LAMPS, OTHER ELECTRICAL COMPONENTS, OR WORKING WITH OR ADJUSTING THE VENDING MECHANISM. FAILURE TO COMPLY WITH THESE INSTRUCTIONS MAY SUBJECT THE USER TO THE RISK OF ELECTRICAL SHOCK OR MECHANICAL INJURY, WHICH CAN BE SERIOUS OR FATAL.

ELECTRIC POWER NEEDED

Refer to the cabinet serial number plate to determine the proper voltage and frequency the machine. In the US and Canada this is 120 VAC, 60 Hertz, 1P. In Europe, Australia, and other export countries, this is 220/230/240Vac, 50Hz, 1P depending upon your country voltage. The serial plate also specifies the ampere rating of the machine. This machine must be plugged into a properly rated receptacle with its own circuit protection (fuse or circuit breaker).

Equipment Nominal Power Requirements -

120V / 10.2 A = *1224W (1.224kw)

220V / 5.8 A = *1276W (1.276kw)

240V / 5.8 A = *1392W (1.392kw)

*Note: Watts = V X A

DO NOT USE AN EXTENSION CORD.

POWER SUPPLY CORD and GROUNDING REQUIREMENTS

In accordance with the National Electrical Code and Underwriters Laboratories Inc., domestic vending machines are equipped with a three-wire power supply cord and Ground Fault Circuit Interrupter (GFCI). The GFCI device is provided as part of the power supply cord and is either incorporated directly into the plug or mounted on the cord adjacent to the plug.

WARNING

- The GFCI protects against current leakage caused by ground faults. The GFCI is not designed to protect against over current or short circuits.
- **DO NOT** use the TEST and RESET buttons on the GFCI as an ON/OFF switch.
- The vending machine supply cord **MUST** be plugged directly into a properly grounded, 3 wire receptacle that is properly protected by a fuse or circuit breaker. If the receptacle will not accept the power cord plug, it must be replaced with a properly grounded, 3 wire receptacle in accordance with the National Electrical Code and Local Codes and Ordinances. The work should be done by a qualified electrician. **DO NOT USE A 3 WIRE TO 2 WIRE ADAPTOR**



DO NOT REMOVE THE GROUND PIN ON THE PLUG OR IN ANY WAY BYPASS, MODIFY, DEFEAT, OR DESTROY THE GROUNDING SYSTEM OF THE VENDING MACHINE

- **DO NOT USE WITH AN EXTENSION CORD.**
- **DO NOT REMOVE THE WARNING TAG ATTACHED TO THE POWER SUPPLY CORD.**
- The GFCI must be tested frequently and before each use in accordance with the instructions provided on the GFCI device. **IF THE GFCI DOES NOT PASS THE TEST, DO NOT USE THE MACHINE.** Unplug the supply cord from the receptacle and call the Crane Merchandising Systems Technical Support Group for assistance at 1-803-266-5001.

It is recommended that the machine be located so that the GFCI device will be accessible after the machine is installed. After installation, visually inspect the GFCI and power supply cord to be sure it is not crushed, pinched, or stretched.

Protect the power supply cord during transportation and use. Periodically inspect the power supply cord for damage. If the cord or plug is worn or damaged, it must be replaced with a power supply cord of the same type, size and specification as originally provided with the machine. **DO NOT USE THE VENDING MACHINE UNTIL THE WORN OR DAMAGED CORD IS REPLACED.**

FAILURE TO COMPLY WITH THESE INSTRUCTIONS MAY SUBJECT THE USER TO THE RISK OF INJURY OR ELECTRICAL SHOCK WHICH CAN BE SERIOUS OR FATAL. PERIODICALLY INSPECT THE POWER SUPPLY CORD FOR DAMAGE. IF THE CORD BECOMES DAMAGED IT MUST BE REPLACED WITH THE SAME SIZE AND TYPE CORD. CONTACT CRANE MERCHANDISING SYSTEMS FOR ASSISTANCE.



**PLACING THE VENDER ON LOCATION
!! CAUTION !!**



DO NOT TRANSPORT THE VENDER TO OR FROM THE LOCATION LOADED WITH PRODUCT. DAMAGE TO THE VENDER MAY RESULT.

The vender must be located on a solid, flat, and level surface. Ensure the flooring can bear the weight of a fully loaded vender (approx. 1512 lbs or 686 kg). The vender must be positioned close enough to an electrical outlet that an extension cord is not required. If the machine will be subject to user misuse or vandalism, it is recommended that the vender be secured to the floor or wall as described in Technical Bulletin 344. Do not transport the vender to or from customer locations loaded with product, as damage may result due to excessive weight. Be sure to test vender for proper operation before putting in to service on location. Call the Crane Merchandising Systems Technical Service Department or your Crane Merchandising Systems Representative for assistance.

ACCEPTABLE AMBIENT OPERATING TEMPERATURE RANGE.

DNCB448 & DNCB640 equipment manufactured by Crane Merchandising Systems is designed to work properly in a temperature range of 75°F to 90°F (23°C to 32°C) in still air 65% R.H. non-condensing.

LEVEL THE VENDER

When the vender is level, the door can be opened to any position and it will not move by itself. Open the door to several different positions before deciding the vender is level. A carpenter's level will help verify the machine is level. Leveling legs are adjusted using a wrench or socket 1 1/2" or 38 mm in size. Make sure that all leveling legs are in contact with the floor. If you cannot level the vender in its current location, select another location. **NEVER PLACE OBJECTS UNDER THE LEVELING LEGS OF THE VENDER.**

DANGER

THE VENDER MUST BE PROPERLY LOCATED AND LEVELED. IF THE MACHINE WILL BE SUBJECT TO USER MISUSE OR VANDALISM IT IS RECOMMENDED THAT THE VENDER BE SECURED TO THE FLOOR OR WALL AS DESCRIBED IN CRANE MERCHANDISING SYSTEMS TECHNICAL BULLETIN 344 TO MINIMIZE THE RISK OF INJURY OR DEATH FROM TIPPING. CALL THE CRANE MERCHANDISING SYSTEMS TECHNICAL SERVICE DEPARTMENT OR YOUR CRANE MERCHANDISING SYSTEMS REPRESENTATIVE FOR ASSISTANCE.



SPACE THE VENDER

Do not block the rear of the vender. Keep the vender 4 inches (10 cm) from the wall to ensure adequate airflow from the condenser and compressor. At the front of the vender, make sure that nothing obstructs the air intake at the bottom of the main door. At the rear of the vender, make sure nothing obstructs the air exhaust at the bottom of the cabinet.



WARNING

TO AVOID THE POSSIBILITY OF A FIRE HAZARD, DO NOT STORE ANYTHING OR ALLOW DEBRIS OF ANY KIND TO ACCUMULATE IN THE BOTTOM OF THE DOOR, IN AND AROUND THE REFRIGERATION COMPARTMENT OF THE CABINET, OR IN FRONT OF THE EVAPORATOR AND CONDENSER COILS.

COIN CHANGERS & OTHER ACCESSORIES

The vender must have an MDB coin changer installed and can have an MDB bill acceptor installed as well. If the MDB coin changer and other MDB accessories are not factory installed, refer to the instructions received from the manufacturer of the MDB coin changer and other MDB accessories for proper set-up and installation.

For additional information about coin mechanisms, refer to the specific manufacturer's instructions.

SETTING THE TEMPERATURE CONTROL

This vender is equipped with an electronic temperature sensor. The temp sensor is factory pre-set to maintain a cabinet temperature of 37° Fahrenheit (2.7°C). It is also a good practice to ensure the proper operating temperature prior to installing the vender on location. To set the temperature, apply power to the vender and allow it to run for several hours with the door closed or until the minimum cabinet temperature is achieved. Then, using the method below, verify the temperature inside the cabinet. In programming scroll to and enter Environmental Controls, then scroll to and enter Refrigeration, then scroll to and enter Display, set this mode to "On". Important note: Sales Message must also be set to "On" for the temperature to be displayed.

LOADING CHANGE TUBES

Open the main door and enter the Service Mode. Advance to "Fill Coin Mech" mode in the "Cash Settings" menu in Programming.

Load the coin mechanism with coins by inserting coins in the coin mech's separator. The display will show the total value of coins as they are inserted.

Note: A low coin level in the coin tubes will interfere with operation of the bill validator.

For additional information about coin mechanisms, refer to the specific manufacturer's instructions.

Loading Product

The Vender is designed to vend a wide range of packages. All Venders are shipped ready to vend packages according to customer orders. To vend an alternative package in the vender, contact Crane Merchandising Systems Service Dept. or your Representative for Assistance. You may also search the package type you wish to vend at www.dixienarco.com.

INITIAL LOADING

To ensure proper vending, make sure columns are set to vend the proper packages. When loading the narrow columns, lay the first row of packages on the Load Bar.

Correct loading will prevent service calls and ensure proper vending.

After loading the vender for the first time, ensure the vender is loaded and primed. Priming is done in programming. **The depth must also be programmed depending on the package to be vended. Cans may be programmed up to 4 deep.**

NOTE: To ensure proper airflow through the evaporator and the proper operation of the Vend Sensor, **DO NOT** place packages (or other foreign objects) in the bottom of the tank.

SERVICE NOTE

Battery Backup (SBC)

The Single Board Controller is equipped with a battery backup which is used to retain information programmed in the system (pricing, time, date, etc.) in case of power interruptions or any time the main power is off. When the vender is shipped, the battery is connected and memory is being maintained.

Disconnect the battery if the vender will be stored for a long period of time. The following steps will guide you through this procedure.

- Remove power from the vender by unplugging the main power cord from the wall receptacle.
- Locate the Control Board on the main door. Remove the battery from its holder (B1).

SBC PROGRAMMING METHOD

2012
DNCB640/ DNCB448

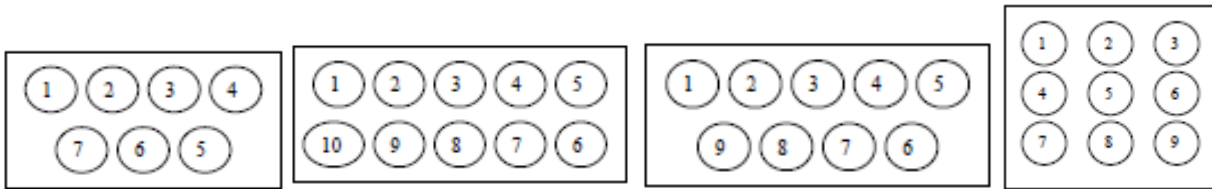

The controller has two modes of operation:
NORMAL and SERVICE.

NORMAL MODE:

In Normal Mode, on power up display will show the software version installed in vender for 10 Seconds, then change to **"Ice Cold Drink"** message, **Product Price**, **"Sold Out"**, **Credit Value**, or decimal point. If the right most decimal is flashing, this indicates an error or problem recognized in the vender. When money is inserted, the display indicates the total amount of the deposit. The select buttons are used to select the product. In normal mode you may access an external menu for reading historical sales total, product total, product total by selection, sales by price totals, and machine temperature.

Note: If **"Enter Number of Columns"** appears on the display on power up with the door open, you will need to program the vender model number in the controller. Refer to Setting the Vender Type on page 2.

Important: Vender has Energy Star software that turns the lights out after 10 hours of inactivity. The lights come back on once the unit is coined or any selection button is pressed. The feature is non adjustable and cannot be disabled.

SERVICE MODE:

The Service Mode is entered when the vender door is open and the service switch is pressed. The display will show a list of error codes for errors that have occurred since the door was last opened. **"Jammed Column #"** is a vend mechanism jammed, **"Select Switch #"** is a select switch problem, **"Refrigeration"** is a refrigeration or temp sensor problem, **"Vend Sensor"** is a Vend Sensor problem and **"Door Switch"** is a door switch open problem. To acknowledge an error, press select button 1, at this time you will enter the service menu. The display will show **"Historical Data"** at this time. Some of the menu items have sub-menus.

To move through the menus and sub-menus follow these instructions. To:

- | | |
|--------------------|---|
| MOVE THROUGH MENU: | Press select buttons 1 & 2 simultaneously to scroll down through the menu. While scrolling down through menu, release for 2 seconds, press select buttons 1 & 2 simultaneously to scroll up through menu. |
| ENTER SUB-MENU: | Press and hold select button 1 to enter a sub-menu. |
| EXIT SUB-MENU: | With "Return" on display, press and hold select button 1 to exit a sub-menu. |

EXIT SERVICE MODE:

Closing the inner door, pressing button 1 when **"Return"** is displayed at the top menu level, or a five-minute inactivity time-out will exit the service mode.

FRONT PANEL PROGRAMMING SERVICE MENU

Historical Data

This function shows the user the vender accounting over the life of the vender. Use the following select buttons to view the total sales in dollars, total number of vends and the total number of vends for each selection.

Press Select Button 1: Shows the historical total cash sales for the life of the vender.

Press Select Button 2: Shows the historical total number of vends.

Press Select Button 3: Shows the historical number of vends by selection. Each selection automatically scrolls across the display.

Press & hold select buttons 1 & 2 simultaneously to move to the next item on the menu.

Resettable Data

This function shows the user the vender accounting data since the last counter reset. This data can be reset either from the menu or by DEX interrogation.

Press Select Button 1: Shows the total cash collected since the last counter reset

Press Select Button 2: Shows the total number of vends since the last counter reset.

Press Select Button 3: Shows the total number of vends by selection since the last counter reset. Each selection automatically scrolls across the display.

Press Select Button 4: This button zeros the interval data described above. Hold select button "4" for 5 seconds, "the display will go blank" then "**Counters Reset**" will be displayed. At this time, all interval data will return to "0".

Press & hold select buttons 1 & 2 simultaneously to move to the next item on the menu.

Set Price

This function is used to set the price of each selection. When a select button is pressed, the price for that selection will be displayed. If the button is held in, the price will increment or decrement. To change from increment to decrement, release the select button and press it again. To set all selections for the same price: set the desired vend price on select #1, then simultaneously press and hold buttons 3 & 4, the price set for select #1 will be displayed. After 5 seconds the display will show "**Single Price Set**", this will change the vend price of all selections, both primary and secondary, to the price programmed to button #1.

Note: The SBC multi-pricing capability allows you to set all the selections to any price in the range of \$0.00 to \$99.95.

Press & hold select buttons 1 & 2 simultaneously to move to the next item on the menu.

Cash Settings

This function is used to configure credit handling rules for the vender. To move to "**User Menu**", press & hold select buttons 1 & 2 simultaneously. Press button 1 to enter "**Cash Settings**" Menu. The following are sub-menus of the Cash Settings: "**Fill Coin Mech**", "**Dump Coin Mech**", "**Coin Rules**", "**Escrow**", "**Multi Vend**", and "**Return**".

Fill Coin Mech:

This function is used to count coins loaded in the top (separator) of the coin mech. When "**Fill Coin Mech**" is displayed the coin mech will accept tubed coins. When the first coin is inserted, "**Fill Coin Mech**" will be replaced with the cash value of coins in the coin tubes. The total value of the coins inserted will be displayed and will be counted in the DEX audit data, so the controller knows exactly how much change is in the coin mech. Press select button 1 to return to "**Fill Coin Mech**".

Press & hold select buttons 1 & 2 simultaneously to move to the next item on the menu.

Dump Coin Mech:

This function is used to dump coins from the coin mechanism. Press select button #1 to enter “**Dump Coin Mech**” mode and the lowest coin value dispensable will show on the display. Press and hold select buttons 1 & 2 simultaneously to scroll through the different coin values available to dump coins. Press and hold select button #1 to dump the coins whose value is shown on the display. Press and hold select buttons 1 & 2 simultaneously until “**Return**” shows on the display. Press select button #1 will return to “**Dump Coin Mech**”.

If a level 3 coin mech with Alternate Payout mode is installed, the coin mech will stop dispensing coins when the coin mech’s coin count reaches 0.

Coin Rules:

This condition is used to allow the exact change condition to be turned on or off. When “**Off**” the controller will not go into an exact change condition. This will allow bills or coins to be accepted regardless of the ability to pay back non-refundable currency. When turned “**On**”, the controller will set the exact change condition based on the ability to pay back non-refundable currency (i.e. Coins, paper). To show current condition press select button 1. Press and hold select button 1 to toggle “**Coin Rules**” “**On**” and “**Off**”.

Escrow:

This function supports 4 (four) escrow options. Pressing select button 1 will show the current escrow setting. Press and hold select button 1 to scroll through the available Escrow options and set the escrow mode to the setting displayed when select button1 is released.

“Price 1”

This escrow condition is forced vend option 1 (“Escrow to Price”). All dollar bills will be stacked. No cancel sale is allowed once minimum vend price is met or exceeded.

“Price 2”

This escrow condition is forced vend option 2 (“Escrow No Cancel”) with all bills stacked, and no cancel sale allowed unless the vender is in exact change and the maximum vend price is exceeded. Note: Any money entered below the vend price cannot be returned.

“Select 4”

This escrow condition is “Escrow to Select” with all the dollar bills being stacked. Cancel sale will return the deposit from the coin changer (i.e.4 quarters).

“Select 1”

This escrow condition is “Escrow to Select Dollar Bills” with the last dollar bill that meets or exceeds maximum vend price being escrowed in the validator. Cancel sale will return the held dollar bill and any amount over \$1 will be returned from the coin changer.

Press & hold select buttons 1 & 2 simultaneously to move to the next item on the menu.

Multi Vend:

This function, when turned on, allows credit to be retained after a vend so the customer can vend from another selection. (i.e..50 vend price, put in \$1.00, push a select button and vends, .50 still shows on the display, push a second select button and vends). Credit is cancelled after 5 minutes of inactivity. There is unlimited acceptance. If a customer wants their credit (money) back, the coin return lever must be pressed. To show the current “**Multi Vend**” condition, press select button 1 and the display will show the current setting. Press and hold button 1 to toggle “**Multi Vend**” “**On**” and “**Off**”.

Press and hold select buttons 1 & 2 simultaneously to move to “**Return**”.

Return:

Press and hold button 1 to return to “**Cash Settings**”.

User Menu:

This function is used to configure the vender to operate in a fashion best suited for the vender location. To move to “**Diagnostics**”, press & hold select buttons 1 & 2 simultaneously, to enter the “**User Menu**” sub-menus press select button 1. The following are sub-menus of the “**User Menu**” for a machine with AC motors: “**Space To Sales**”, “**Column**”, “**Time**”, “**Language**”, “**Electronic Counter**”, “**Limited Access**”, “**Secondary Price**”, “**Environmental Controls**”, “**Light**”, “**Refrigeration**”, “**Free Vend**”, “**Override**”, “**Sales Message**”, “**Recharge**”, and “**Return**”. The “**Column**” sub-menu prompt will only be available in machines with DC motors.

Space To Sales

To view the space to sales condition, press select button 1 and display will show “**Selection 1**”. Alternating with columns assigned to that select button. Press select buttons 1 & 2 simultaneously to scroll through the available select buttons to view columns assigned and “**Return**”.

To change space to sales:

Press select button 1 at the “**Selection #**” prompt and “**Column ## #**” (column edit routine) will be displayed, where the **##** is the column to be added or deleted to the select button and the third **#** is “**0**” for not assigned or “**1**” for assigned to that selection. Press select button 1 with “**Column ## #**” on the display to toggle between “**Column ## 0**” and “**Column ## 1**”. With the setting you wish to use showing on the display, press select buttons 1 & 2 to scroll to next selection to add/delete columns. Press select button 1 at the “**Return**” prompt when selecting columns to enable, will return to “**Selection #**”. Press select button 1 at the “**Return**” prompt when choosing what selection to set for Space to Sales, will return to “**Space to Sales**”.

Note: You must be in the “**Selection**” prompt to get to the “**Return**” mode that scrolls to “**Space To Sales**”.

Press & hold select buttons 1 & 2 simultaneously to move to the next item on the menu.

Column - This prompt only appears on machines with DC motors.

Select this prompt to set column depth, package type and vend angles if the package type is custom. This will scroll through the list of **Columns 1--- 9**, “**ALL**” or “**Return**” to select what column(s) will have its settings changed. Pressing button 1 will display “**Column #**” where **#** represents the column number. Pressing select buttons 1 & 2 simultaneously will scroll through the columns.

Press select button 1 to scroll to “**Package**”

“**Package**” - is the next prompt. Press select buttons 1 & 2 simultaneously after entry into this sub-menu will toggle between “**Package**” and “**Return**”. Selecting “**Package**” allows setting the package type for the column selected in the column prompt. Pressing select button 1 will show current package setting. (i.e. **1, 2, 3, ..., Custom, and Return**). Press select buttons 1 & 2 simultaneously to scroll through the package settings.

Press select button 1 to select the package type.

If a predefined package type(1, 2, 3, 4, 5, 6, 7, or 8) is selected

Reference Pre-Set Package Settings on page 22.

After the package type has been selected, “**Key 1 = Prime, Key 2 = Exit**” will be displayed. Press button 1 to prime the column with product or button 2 to exit without priming the column. If select button 2 is pressed the column will be marked as jammed and will prime when the door is closed.

“Hold Angle” - Will only be displayed if the package type selected is “custom”.

This allows setting the hold angle for the column selected in the column prompt. Press select button 1 to display the current hold angle “**Hold Angle ###**”. Press select buttons 1 & 2 simultaneously to increase the Hold Angles Number. Release and Press Selection Buttons 1 and 2 again to decrease the Hold Angle Number. Press select button 1 to select the displayed hold angle. “**Depth**” will be displayed after the hold angle is set.

“Depth” - Will only be displayed if the package type selected is “custom”.

This allows setting the product depth for the column selected in the column prompt. The current product depth “**Depth #**” is displayed when select button 1 is pressed. Press select buttons 1 & 2 simultaneously to scroll through available product depths (1-5). Press select button 1 to select the displayed depth.

“Vend Angle” - Will only be displayed if the package type selected is “custom”.

This allows setting the vend angles for the column selected in the column prompt. “**Vend Angle # ###**” will be displayed where the first # is the product number in the column and ### is the Vend Angle Number for that product. The user will be prompted to enter same number of vend angles as was entered at the “**Depth**” prompt. After the last vend angle is entered the display will show “**2 = Exit, 1 = Prime**”. Press button 1 to prime the column with product or 2 to exit with out priming the column. If select button 2 is pressed the column will be marked as jammed and will prime when the door is closed.

Return

Pressing select button 1 will return to “**Column#**”

Press and hold select buttons 1 & 2 simultaneously to move to the next item on the menu

Time

This function is used to set the year, month, day, hour/minute (military 24 hour clock), and daylight savings time. Press select button 1 and “**Year**” will show on display. Press select buttons 1 and 2 simultaneously to scroll through all “**Time**” sub-menus.

“Year”- Year Setting (2000 to 2099)

Press select button 1 the current year setting will show on display.

Press and hold select button 1 to increment the year setting (2000 to 2099).

Release select button 1 and press and hold again will decrement the year setting.

Release the select button with the display showing the year you wish to use and display will return to “**Year**”.

Press select buttons 1 & 2 simultaneously to scroll to “**Month**”.

“Month” - Month Setting (01 to 12)

Press select button 1 and the current 2-digit month setting will show on display.

Press and hold select button 1 to scroll through the month settings. (01 = Jan. to 12 = Dec).

Release the select button with the display showing the month you wish to use and display will return to “**Month**”.

Press select buttons 1 & 2 simultaneously to scroll to “**Day**”.

“Day” - Day of Month Setting (1 to 31)

Press select button 1 and the current 2-digit day of month setting will show on display.

Press and hold select button 1 to scroll through the day of month settings (1 to 31).

Release select button 1 and press and hold again will decrement the day of month setting.

Release the select button with the display showing the day of month setting you wish to use and display will return to “**Day**”.

Press select buttons 1 & 2 simultaneously to scroll to “**Hour/Minute**”.

“Hour/Minute” - Hour and Minute Setting (0000 to 2359)

Press select button 1 and the current 4-digit hour and minute setting will be displayed (24 hour).

Press and hold select button 1: Set Hours

Press and hold select button 2: Set Minutes

Press select buttons 1 & 2 simultaneously to move to “**Daylight Savings Time**” menu.

Daylight Savings Time

Press select button 1 and the current setting will show on the display.

Press and hold select button 1 to scroll through the **“Daylight Savings Time”** options listed:

“American” – North American rules – Set forward 1 hour at 2:00 am on the first Sunday in April; Set backward 1 hour at 2:00 am on the last Sunday in October.

“European” – European rules – Set forward 1 hour at 1:00 am on the last Sunday in March; Set backward 1 hour at 1:00 am on the last Sunday in October.

“Australian” – Australian rules – Set forward 1 hour at 1:00 am on the first Sunday in October; Set backward 1 hour at 1:00 am on the last Sunday in March.

“Off” – Off Rules – Daylight savings time change will not be made.

Release the select button with the display showing the **“Daylight Savings Time”** setting you wish to use and display will return to **“Daylight Savings Time”**.

Press and hold select buttons 1 & 2 simultaneously to move to **“Return”**.

Return:

Press select button 1 to return to **“Time”**.

Language

This function is used to set the language that will be used for sales mode messages. To display the current language selected, press select button 1. To change the language selected, press & hold select button 1 to scroll through the language menu. Once the desired language is shown on the display, release the button. The display will then return to **“Language”**.

English

French

German

Italian

Portuguese

Spanish

Slovene

Finnish

Norwegian

Turkish

Press and hold select buttons 1 & 2 simultaneously to move to the next item on the menu.

Electronic Counter

This function is used to set the four (4) button code that will show historical cash sales, historical total vends, historical product counts by selection, historical product counts that have occurred for prices, and cabinet temperature when the vender is in sales mode. Press select button 1 to view the current four (4) button code.

To change **“Electronic Counter”** four button code:

At **“Electronic Counter”** press select button 1, **“####”** (representing current four button code) will show on display (**“4231”** is the factory default code). Press and hold select button 1 until the far left digit is replaced by an **“*”** indicating it can be changed. Press the select button desired for the first digit of the code. The next digit will be replaced by an **“*”** press the select button desired for that digit of the code. Continue this process until all 4 digits are set. After the last digit is entered the display will return to **“Electronic Counter”**

Note: The four-button code used must be select buttons 1 through 9 only.

Enter the four button code while in sales mode to view the data. Once entered the listed data is available from the front of the vender:

- Press select button 1: Show historical cash sales.
- Press select button 2: Show historical total vends.
- Press select button 3: Show historical product counts by selection.
- Press select button 4: Show historical cash sales by selection
- Press select button 5: Show temperature inside the cabinet.
- Press select button 6: Returns to sales idle mode (sales vender operation).

Note: There is a thirty (30) second time-out that will return the vender to sales mode if no select buttons are pressed.

Press & hold select buttons 1 & 2 simultaneously to move to the next item on the menu.

Limited Access

This function is used to program the vender to use the Limited Access Features. To move to "**Secondary Price Menu**" press & hold select buttons 1 & 2 simultaneously, to enter the sub-menu press Select Button 1. The following are sub-menus of the Limited Access Menu: "**Selects**", "**Days**", "**Start 1**", "**Stop 1**", "**Start 2**", "**Stop 2**", and "**Return**".

Selects

This function is used to set selection(s), which, will be limited during certain periods of the day. To view the selection setting condition, press select button 1. The display will show "**Selects## #**" where **##** is the selection number and **#** is a "**0**" or "**1**" depending on whether the selection is enabled (1) or disabled (0). Press and hold select button 1 to toggle between "**0**" & "**1**". Press select buttons 1 & 2 simultaneously to scroll through all available select buttons, "**NONE**", "**ALL**", and "**Return**". Pressing select button 1 when "**ALL**" is displayed will cause the display to change to "**On**" when all selections have been enabled. Pressing select button 1 when "**NONE**" is displayed will cause the display to change to "**Off**" when all selections have been disabled. Press select button 1 at the "**Return**" prompt returns to "**Selects**".

Press & hold select buttons 1 & 2 simultaneously to move to the next item on the menu.

Days

This function is used to set the days of the week to be affected by limited access.

Day of Week:	Sunday	Wednesday	Saturday	Return
	Monday	Thursday	All Days	
	Tuesday	Friday	No Days	

Press select button 1 and "**Monday #**" will show on the display, where **#** is "**0**" (disable) or "**1**" (enable). Press and hold select button 1 to toggle between "**0**" and "**1**". Release the select button with the display showing the setting you wish to use. Press select buttons 1 & 2 simultaneously to scroll through all available days, "**All Days**", "**No Days**", and "**Return**". Pressing select button 1 when "**All Days**" is displayed will cause the display to change to "**On**" when all days have been enabled. Pressing select button 1 when "**No Days**" is displayed will cause the display to change to "**Off**" when all days have been disabled. Press select button 1 at the "**Return**" prompt returns to "**Days**".

Press & hold select buttons 1 & 2 simultaneously to move to the next item on the menu.

Start 1

This function is used to set the hours and minutes to start period 1 limited access. Press select button 1 and the current four-digit hour and minute setting will to be displayed (24 hour).

- Press & hold select button 1: Set Hours
- Press & hold select button 2: Set Minutes

Press select buttons 1 & 2 simultaneously to move to the next item in the menu.

Stop 1

This function is used to set the hours and minutes to stop period 1 limited access. Press select button 1 and current four-digit hour and minute will be displayed. (24 hour).

Press & hold select button 1: Set Hours

Press & hold select button 2: Set Minutes

Press select buttons 1 & 2 simultaneously to move to the next item in the menu.

Start 2

This function is used to set the hours and minutes to start period 2 limited access. Press select button 1 and the current four-digit hour and minute setting will be displayed (24 hour).

Press & hold select button 1: Set Hours

Press & hold select button 2: Set Minutes

Press select buttons 1 & 2 simultaneously to move to the next item in the menu.

Stop 2

This function is used to set the hours and minutes to stop period 2 limited access. Press select button 1 and the current four-digit hour and minute setting will be displayed (24 hour).

Press & hold select button 1: Set Hours

Press & hold select button 2: Set Minutes

Press select buttons 1 & 2 simultaneously to move to the next item in the menu.

Return

Press select button 1 to return to "**Limited Access**".

Press & hold select buttons 1 & 2 simultaneously to move to the next item on the menu.

Secondary Price

This function is used to program a second price for each selection. To move to "**Environmental Controls**", press & hold select buttons 1 & 2 simultaneously. To enter the sub-menu press select button 1. The following are sub-menus of the Secondary Price Menu: "**Price**", "**Days**", "**Start**", "**Stop**", and "**Return**".

Price

This function is used to set the price of each selection. When a select button is pressed, the price for that selection will be displayed. If the button is held in, the price will increment or decrement. To change from increment to decrement, release the select button and press it again.

Note: The SBC multi-pricing capability allows you to set all selections to any price in the range of \$0.00 to 99.95.

Press & and hold select buttons 1 & 2 simultaneously to move to the next item on the menu.

Days

This function is used to set the days of the week to be affected by secondary pricing.

Day of Week:	Sunday	Wednesday	Saturday	Return
	Monday	Thursday	All Days	
	Tuesday	Friday	No Days	

Press select button 1 and "**Monday #**" will show on the display, where # is "**0**" (disable) or "**1**" (enable). Press and hold select button 1 to toggle between "**0**" and "**1**". Release the select button with the display showing the setting you wish to use. Press select buttons 1 & 2 simultaneously to scroll through all available days "**All Days**", "**No Days**", and "**Return**". Pressing select button 1 when "**ALL Days**" is displayed will cause the display to change to "**On**" when all days have been enabled. Pressing select button 1 when "**No Days**" is displayed will

cause the display to change to **“Off”** when all days have been disabled. Press select button 1 at the **“Return”** prompt returns to **“Days”**.

Press & hold select buttons 1 & 2 simultaneously to move to the next item on the menu.

Start

This function is used to set the hours and minutes to start secondary pricing. Press select button 1 and the current four-digit hour and minute setting will be displayed. Press and hold select button 1 to change the hour setting, press button 2 to change the minute setting.

Press select buttons 1 & 2 simultaneously to move to the next item in the menu.

Stop

This function is used to set the hours and minutes to stop secondary pricing. Press select button 1 and the current four-digit hour and minute setting will be displayed. Press and hold select button 1 to change the hour setting, press button 2 to change the minute setting.

Press select buttons 1 & 2 simultaneously to move to the next item in the menu.

Return

Press button 1 to return to **“Secondary Pricing”**.

Press buttons 1 & 2 to scroll to the next item in the menu

Environmental Controls

This allows the user to view the energy conservation menu **“Lighting”, “Refrigeration”,** and also the **“Relay”** test menu. **When this is programmed to “Off” you will not see “Lighting”, Refrigeration or Relay Test.** Press select button 1 and the current setting will be displayed (**On or Off**). Press and hold select button 1 to toggle between **“On”** and **“Off”** (**This feature is “Off” from the factory**). To move to **“Light”**, press & hold select buttons 1 & 2 simultaneously with this feature on. To move to **“Free Vend”**, press & hold select buttons 1 & 2 simultaneously with this feature off.

Light

This function is used to turn the lights off during certain periods of the day. To enter the sub-menu press select button 1. The following are sub-menus of the Light Menu: **“Days”, “Start”, “Stop”, “Enable”,** and **“Return”**. To move to **“Refrigeration”**, press & hold select buttons 1 & 2 simultaneously.

Pressing select button 1 will enter **“Days”**.

Days

This function is used to set the days of the week to turn lights off.

Day of Week:	Sunday	Wednesday	Saturday	Return
	Monday	Thursday	All Days	
	Tuesday	Friday	No Days	

Press select button 1 and **“Monday #”** will show on the display, where **#** is **“0”** (disable) or **“1”** (enable). Press and hold select button 1 to toggle between **“0”** and **“1”**. Release the select button with the display showing the setting you wish to use. Press select buttons 1 & 2 simultaneously to scroll through all available days, **“All Days”, “No Days”,** and **“Return”**. Press select button 1 at the **“Return”** prompt returns to **“Days”**.

Press & hold select buttons 1 & 2 simultaneously to move to the next item on the menu.

Start

This function is used to set the hours and minutes to start lighting routine.

Press select button 1 and the current four-digit hour and minute setting will be displayed. (24 hour).

Press & hold select button 1: Set Hours

Press & hold select button 2: Set Minutes

Press select buttons 1 & 2 simultaneously to move to the next item on the menu.

Stop

This function is used to set the hours and minutes to stop lighting routine.

Press select button 1 and the current four-digit hour and minute setting will be displayed.
(24 hour)

Press & hold select button 1: Set Hours

Press & hold select button 2: Set Minutes

Press select buttons 1 & 2 simultaneously to move to the next item on the menu.

Enable

This function is used to allow the lighting routine to go in to affect.

Press select button 1 and the current setting will be displayed (**On** or **Off**).

Press and hold select button 1 to toggle between "**On**" and "**Off**".

Release the select button showing the setting you wish to use and display will return to "**Enable**".

Press select buttons 1 & 2 to scroll to "**Return**".

Return

Press select button 1 to return to "**Light**".

Press & hold select buttons 1 & 2 simultaneously to move to the next item on the menu.

Refrigeration

This function is used to electronically control the refrigeration operations of the vender. . To enter the sub-menu press select button 1. The following are sub-menus of the Refrigeration Menu: "**Temperature**", "**Celsius or Fahrenheit**", "**Display**", "**Days**", "**Start**", "**Stop**", "**Storage Temperature**", "**Storage Enabled**", and "**Return**". To move to "**Free Vend**", press & hold select buttons 1 & 2 simultaneously. Press select button 1 will enter "**Temperature**".

Temperature

(Default Temperature 37°F/15°C)

This function is used to set the average product temperature for initial pull down and reload recovery (32-41 Fahrenheit or 0-5 Celsius).

Press select button 1 and "**tt.tx**" will show on the display where "**x**" is Fahrenheit or Celsius and "**tt.t**" is the degrees.

Press and hold select button 1 to increase or decrease the number by 1F or 0.5C. Release select button with the display showing the temperature you wish to use and the display will return to "**Temperature**".

Press select buttons 1 & 2 to scroll to "**Celsius or Fahrenheit**".

Celsius or Fahrenheit

This function is used to set the degree reading to Fahrenheit or Celsius.

Press select button 1 and the current setting will show on the display. Press and hold select button 1 to toggle between "**Fahrenheit**" and "**Celsius**". Release the select button with the display showing the setting you wish to use and display will return to "**Celsius or Fahrenheit**".

Press select buttons 1 & 2 to scroll to "**Display**".

Display

This function is used to enable the Temperature to be displayed following the "**Ice Cold Drink**" message. "**Sales Message must also be set to "ON" for the temperature to be displayed.**"

Press select button 1 and the current setting will be displayed (**On** or **Off**). Press and hold select button 1 to toggle between "**On**" and "**Off**".

Press & hold select buttons 1 & 2 simultaneously to move to the next item on the menu.

Days

This function is used to set the days of the week to use Temperature Setting Routine.

Day of Week:	Sunday	Wednesday	Saturday	Return
	Monday	Thursday	All Days	
	Tuesday	Friday	No Days	

Press select button 1 and "**Monday #**" will show on the display, where # is "**0**" (disable) or "**1**" (enable). Press and hold select button 1 to toggle between "**0**" and "**1**". Release the select button with the display showing the setting you wish to use. Press select buttons 1 & 2 simultaneously to scroll through all available days, "**All Days**", "**No Days**", and "**Return**". Press select button 1 at the "**Return**" prompt returns to "**Days**".

Press & hold select buttons 1 & 2 simultaneously to move to the next item on the menu.

Start

This function is used to set the hours and minutes for storage temperature to become active. Press select button 1 and the current four-digit hour and minute setting will be displayed (24 hour)

Press & hold select button 1: Set Hours
Press & hold select button 2: Set Minutes

Press select buttons 1 & 2 simultaneously to move to the next item on the menu.

Stop

This function is used to set the hours and minutes for storage temperature to become inactive. Press select button 1 and the current 4-digit hour and minute setting will be displayed (24hour).

Press & hold select button 1: Set Hours
Press & hold select button 2: Set Minutes

Press select buttons 1 & 2 simultaneously to move to the next item on the menu.

**Storage Temperature
(Default Temperature 60°F/ 16°C)**

This function is used to set the temperature for product storage (32-75 Fahrenheit or 0-24 Celsius). Press select button 1 and "**tt.tx**" will show on the display where x is Fahrenheit or Celsius and tt.t is the degrees.

Press and hold select button 1 to increase or decrease the number by 1 or 0.5. Release select button with the display showing the temperature you wish to use and display will return to "**Storage Temperature**"

Press select buttons 1 and 2 simultaneously to scroll to "**Storage Enabled**"

Storage Enabled

This function is used to enable the storage setting.

Press select button 1 and the current setting will be displayed (**On or Off**).

Press and hold select button 1 to toggle "**On or Off**".

Release the select button showing the setting you wish to use and display will return to "**Storage Enabled**"

Press select buttons 1 & 2 to scroll to "**Return**"

Return

Press select button 1 at "**Return**" to return to "**Refrigeration**"

Press select buttons 1 & 2 simultaneously to scroll to next item on the menu.

Free Vend

This function is used to set the Free Vend option. Note: For free vend to become active the Key Switch Kit (626,020,44x.x4) must be connected to the Free Vend Switch Connector. Press select button 1 and “**ENABLE**” will show on the display. To move to “**Override**”, press & hold select buttons 1 & 2 simultaneously.

Enable

This function is used to allow the free vend to go in affect.

Press select button 1 and the current setting will be displayed (**On or Off**).

Press and hold select button 1 to toggle between “**On**” or “**Off**”.

Release the select button showing the setting you wish to use and the display will return to “**Enable**”.

Press select buttons 1 & 2 to scroll to “**Display**”

Display

This function is used to show the current number of free vends performed by the controller.

Press select button 1 and “**#**” will show on the display where “**#**” is the number of free vends performed by the controller. Release the select button and display will return to “**Display**”

Press select buttons 1 and 2 simultaneously to scroll to “**Reset**”

Reset

This function is used to reset number of free vends to zero.

Press and hold select button 1 for 5 seconds to reset the number of free vends performed by the controller to zero. Release the select button and the display will return to “**Reset**”.

Press select buttons 1 & 2 to scroll to “**Return**”.

Return

Press select button 1 to return to “**Free Vend**”.

Press & hold select buttons 1 & 2 simultaneously to move to the next item on the menu.

Override

This function is used to allow the Key Switch Kit (626,020,44x.x4) to override some of the settings stored for normal operations. When enabled and the free vend switch is in the closed position, the controller will override “**Free Vend**”, disable vending, disable currency acceptance, display will show “**No Sales**”, and lights will be off. The compressor will continue to keep product at the programmed temperature. Vender will remain in this state until the Override Switch is in the open position.

Press select button 1 and the display will show the current setting for 2 seconds (**On or Off**).

Press and hold select button 1 to toggle between “**On**” - enabled and “**Off**” - disabled.

Release the select button showing the setting you wish to use and display will return to “**Override**”.

To move to “**Sales Message**”, press & hold select buttons 1 & 2 simultaneously.

Sales Message

This function is used to turn on the scrolling message “**Ice Cold Drink**”.

Press select button 1 and the display will show the current setting (**On or Off**).

Press and hold select button 1 to toggle between “**On or Off**”.

Release the select button showing the setting you wish to use and display will return to “**Sales Message**”. Press select buttons 1 & 2 simultaneously to scroll to “**Recharge**”

Recharge -The installed Card Reader must support this option for this feature to work correctly.

This function is used to enable the recharge card setting routine.

Press select button 1 and the display will show the current setting (**On**- recharge card enabled or **Off**- recharge card disabled). Press and hold select button 1 to toggle between “**On**” and “**Off**”.

Release the select button showing the setting you wish to use and display will return to “**Recharge**”.

Press select buttons 1 & 2 simultaneously to scroll “**Return**”

Return

Press select button 1 to return to “**User Menu**”.

Press & hold select buttons 1 & 2 simultaneously to move to the next item on the menu.

Diagnostics

This function allows you to systematically diagnose problems related to the vender. To move to “**Auto Test**” press select buttons 1 & 2 simultaneously, to enter sub-menu press select button 1. The following are sub-menus of Diagnostics Menu:

Vender with DC motors “**Selection**”, “**Home Sensor**”, “**Vend Sensors**”, “**Motors**”, “**Coin Mech**”, “**Note Acceptor**”, “**Display**”, “**Relay**”, “**Jog**”, “**Prime**”, and “**Return**”.

Selection

Press any select button, and the display will indicate the number of the select button pressed.

Press & hold select buttons 1 & 2 simultaneously to the next item on the menu.

Home Sensor - This prompt only appears on machines with DC motors.

Use this to test the Home Sensor on the Motor for any column. Press select button 1 to display “**Column 1**”. Press & hold select buttons 1 & 2 simultaneously to scroll through the columns and “**Return**”. Press button 1 when a column is displayed will cause the displayed column to test that the motor’s home sensor can be detected. The Display will read “**Pass**” or “**Fail**”. Press select button 1 at “**Return**” to return to “**Home Sensor**”.

Press & hold select buttons 1 & 2 simultaneously to move to the next item on the menu.

Vend Sensor - This prompt only appears on machines with DC motors.

Use this to test vend sensor in the machine. Press select button 1 to begin the test and “**TEST CHUTE**” will be displayed. Touch or place an object on the chute. When it is detected “**Chute Pass**” will be displayed. If nothing is detected on the chute, a “**Fail**” or “**CS Error**” message will be displayed.

Press & hold select buttons 1 & 2 simultaneously to move to the next item on the menu.

Motors

Use this test to run any motor in the stack. Press select button 1 and “**Motor 1**” will show on the display. Use the following select buttons to run this test.

Press Select Buttons 1 & 2: Press until desired motor # to run or “**Return**” is shown on the display.

Press Select Button 1: Press to run the selected motor. The display will show “**Vending**” and the selected motor will run until a product passes the Vend Sensor.

Coin Mech

Use this test to check Coin Mech, Coin Chutes, and the Coin Mech payout systems. Inserting any coins enters the coin mech diagnostic function. Only tubed coins (i.e. that can be returned) will be accepted. The value of the coins will be reflected on the Display. Press select button 2 will return any coins inserted and return to “**Coin Mech**”.

Press select buttons 1 & 2 simultaneously to move to the next item on the menu.

Note Acceptor

Use this test to check note acceptor. Inserting a bill enters the Note Acceptor diagnostic function. Bill will be held in escrow and the Display will the notes value. Press select button 2 to stack the bill. Press select button 3 to return the bill. After the note is has been stacked or returned, the display will return to “**Note Acceptor**”.

Press & hold select buttons simultaneously to move to the next item on the menu.

Display

Press select button 1 and the display segments will illuminate in a scrolling manner, or will scroll through a set of text characters and return to “**Display**”.

Press & hold select buttons 1 & 2 simultaneously to move to the next item on the menu.

Relay – Relays can only be tested if the environmental controls package is installed in the vender.

Compressor #

This function allows you to test the relay circuit in the Power Distribution Box for the compressor.

CAUTION: *Disconnect power to the compressor before testing the compressor relay. Failure to disconnect power to the compressor before testing the relay could result in damage to the compressor.*

Press select button 1 and the display will show “**Compressor #**”, where # is the state of the relay **0** = not activated or off; **1**= activated or on. Press select button 1 to toggle the relay “**On**” and “**Off**”. Press select buttons 1 & 2 simultaneously to move to “**Fan**”.

Fan #

This function allows you to test the relay electronic control of the evaporator fan.

Press select button 1 and the display will show “**Fan #**” where # is state of the relay **0** = not activated or on; **1** = activated or off. Press select button 1 to toggle the relay “**On**” and “**Off**”.

Press select buttons 1 & 2 simultaneously to scroll to “**Light**”.

Light #

This function allows you to test the relay electronic control of the lights.

Press select button 1 and the display will show “**Light #**”, where # is the state of the relay **0** = not activated or on; **1** = activated or off. Press select button 1 to toggle the relay on and off. Press select buttons 1 & 2 simultaneously to scroll to “**Return**”.

Return

Press select button 1 to return to “**Relay**”.

Jog Motor - This prompt only appears on machines with DC motors

Press select button 1 the display will show “**Column 1**”. Press select buttons 1 & 2 simultaneously until the desired column is displayed. Selecting the desired column will then prompt for a direction either “**Clockwise**” or “**Counter Clockwise**”. Pressing select 1 & 2 simultaneously will scroll between “**Clockwise**”, “**Counter Clockwise**” and “**Return**”. Pressing select button 1 when “**Clockwise**” or “**Counter Clockwise**” is displayed will jog the motor in that direction. Press select buttons 1 & 2 to scroll to “**Return**”. Press select button 1 at the “**Return**” to return to “**Jog Motor**”.

Press select buttons 1 & 2 to scroll to the next Item.

Prime Column – This prompt only appears on machines with DC motors.

Pressing select button 1 will display “**Column 1**”. Pressing select buttons 1 & 2 simultaneously will scroll to the desired column. Pressing select button 1 when the desired column is displayed will cause that column to be primed. The Display will show “**Prime Column**”. Press select buttons 1 & 2 simultaneously to scroll to “**Return**”. Press select button 1 at “**Return**” will return to “**Prime**”

Press select buttons 1 & 2 simultaneously to scroll to the next Item.

Return

Press select button 1 to return to “**Diagnostics**”.

Press and hold select buttons 1 & 2 simultaneously to scroll to next menu item.

Auto Test

This function is used in Crane Merchandising Systems’s manufacturing process and is not intended for use in the field. Its purpose is a self-test routine to check the SBC components listed. For further details contact Crane Merchandising Systems Factory Service.

Press and hold select buttons 1 & 2 simultaneously to scroll to “**Return**”.

Return

Press & hold select buttons 1 & 2 simultaneously to scroll to “**Return**”.

Press select button 1 to return to Sales mode.

Generic DNCB640/ DNCB448 SBC QUICK REFERENCE MENU PROMPTS

Main Menu	Sub-Menu	Sub-Sub-Menu	Main Menu	Sub-Menu	Sub-Sub-Menu
Historical Data			User con't.	Light	Days
Resettable Data					Start
Set Price					Stop
Cash Settings	Fill Coin Mech				Enable
	Dump Coin Mech				Return
	Coin Rules			Refrigeration	Temperature
	Escrow	Price 1			Celsius or Fahrenheit
		Price 2			Display
		Select 4			Days
		Select 1			Start
	Multi Vend				Stop
	Return				Storage Temperature
User Menu	Space To Sales				Storage Enable
	Column	Package			Return
		Hold Angle		Free Vend	Enable
		Depth			Display
		Vend Angle			Reset
		Return			Return
	Time	Year		Override	
		Month		Sales Message	
		Day		Recharge	
		Hour/Minute		Return	
		Daylight Savings Time	Diagnostics	Selection	
		Return		Home Sensor	
	Language			Vend Sensors	
	Electronic Counter			Motors	
	Limited Access	Selects		Coin Mech	
		Days		Note Acceptor	
		Start 1		Display	
		Stop 1		Relay	Compressor
		Start 2			Fan#
		Stop 2			Light#
		Return			Return
	Secondary Price	Price		Jog Motor	Column #
		Days			Return
		Start		Prime Column	Column #
		Stop			Return
		Return		Return	
	Environmental Controls		Auto test		
			Return		

A. Press and hold select buttons 1 & 2 simultaneously to move through the menu from top to bottom.

B. Press select button 1 to move left/right or enter/exit in the menu, depending on the menu prompt on the display.

PRE-SET PACKAGE SETTINGS

Package settings are a group of settings the machine uses to determine the stopping points for the “rotor” that holds the package. A well set package will allow only one package per vend to be delivered to the customer and when needed will reload the “rotor” for continued operation. Package settings come in two types, Pre-Set and Custom.

DOMESTIC PRE-SET PACKAGE SETTING

Pre-Set Package Settings are groups of settings that have been tested at the factory to work with the widest possible number of the most commonly used packages during venter development and testing. It should be noted that since different packages are used in different regions to perform the same function and that packages change constantly, not all packages are guaranteed to work with a Pre-Set Package Settings and that Package dimensions and shapes change over time. Note: Pre-Set Package Settings are also used for vending other packages not listed on this document.

1. **PACKAGE 1** Package Setting 1 is used for 12 oz Cans that are loaded four deep in the stack. It has one “hold angle” that would be considered to be Home position where all four cans are in the “rotor” and four vend angles that are stopping points which allow only one product to drop out and be delivered to the customer per vend.
2. **PACKAGE 2** Package Setting 2 is used for 20 oz PET bottles in a “Pepsi” type shape. The packages are loaded two deep in the stack. There is one hold angle that would be considered to be “home position” and two vend angles that would allow only one package per vend to be delivered to the customer.
3. **PACKAGE 3** Package Setting 3 is used for 20 oz PET bottles in a “Coke Contour” type shape. The packages are loaded two deep in the stack. There is one hold angle that would be considered to be “home position” and two vend angles that would allow only one package per vend to be delivered to the customer.
4. **PACKAGE 4** Package Setting 4 is used for sports drinks such as 20oz PET Gatorade or Powerade. The packages are loaded two deep in the stack. There is one hold angle that would be considered to be “home position” and two vend angles that would allow only one package per vend to be delivered to the customer.
5. **PACKAGE 5** Package Setting 5 is used for 16 oz or 12 oz Cans set to run at three deep in the stack. There is one hold angle that would be considered to be “home position” and three vend angles that would allow only one package per vend to be delivered to the customer.

Note: Pre-Set Package Setting 6, 7, & 8 were developed for International Packages.

CUSTOM PACKAGE SETTING

CUSTOM PACKAGE A Custom Package is a setting which is determined and entered by the customer in order to operate the machine with a product that can not be vended with a Pre-Set Package Setting. The Custom Package Settings would include, one hold angle, a vend angle for each package listed in the depth setting, and the depth setting.

NOTE: Some package settings may require the use of additional parts and depth settings to vend various products. Depending on the model number, there may be additional parts and changes to the settings within the package setting.

INTERNATIONAL PRE-SET PACKAGE SETTING

Pre-Set Package Settings are groups of settings that have been tested at the factory to work with the widest possible number of the most commonly used packages during vender development and testing. It should be noted that since different packages are used in different regions to perform the same function and that packages change constantly, not all packages are guaranteed to work with a Pre-Set Package Setting and that Package dimensions and shapes change over time. Note: Pre-set Package Settings are also used for vending other packages not listed on this document.

1. **PACKAGE 1** Package Setting 1 is used for International 330ML Cans that are loaded four deep in the stack. It has one “hold angle” that would be considered to be Home position where all four cans are in the “rotor” and four vend angles that are stopping points which allow only one product to drop out and be delivered to the customer per vend.
6. **PACKAGE 6** Package Setting 6 is used for International 500ML PET Coke Contour, Nestea, & Aquarius set to run at two deep in the stack. There is one hold angle that would be considered to be “home position” and two vend angles that would allow only one package per vend to be delivered to the customer.
7. **PACKAGE 7** Package Setting 7 is used for International 500ML PET Fanta set to run at two deep in the stack. There is one hold angle that would be considered to be “home position” and two vend angles that would allow only one package per vend to be delivered to the customer.
8. **PACKAGE 8** Package Setting 8 is used for International 500ML PET AquaBona set to run at two deep in the stack. There is one hold angle that would be considered to be “home position” and two vend angles that would allow only one package per vend to be delivered to the customer.

CUSTOM PACKAGE SETTING

CUSTOM PACKAGE A Custom Package is a setting which is determined and entered by the customer in order to operate the machine with a product that can not be vended with a Pre-Set Package Setting. The Custom Package Settings would include, one hold angle, a vend angle for each package listed in the depth setting, and the depth setting.

NOTE: Some package settings may require the use of additional parts and depth settings to vend various products. Depending on the model number, there may be additional parts and changes to the settings within the package setting.

Factory Default Setting

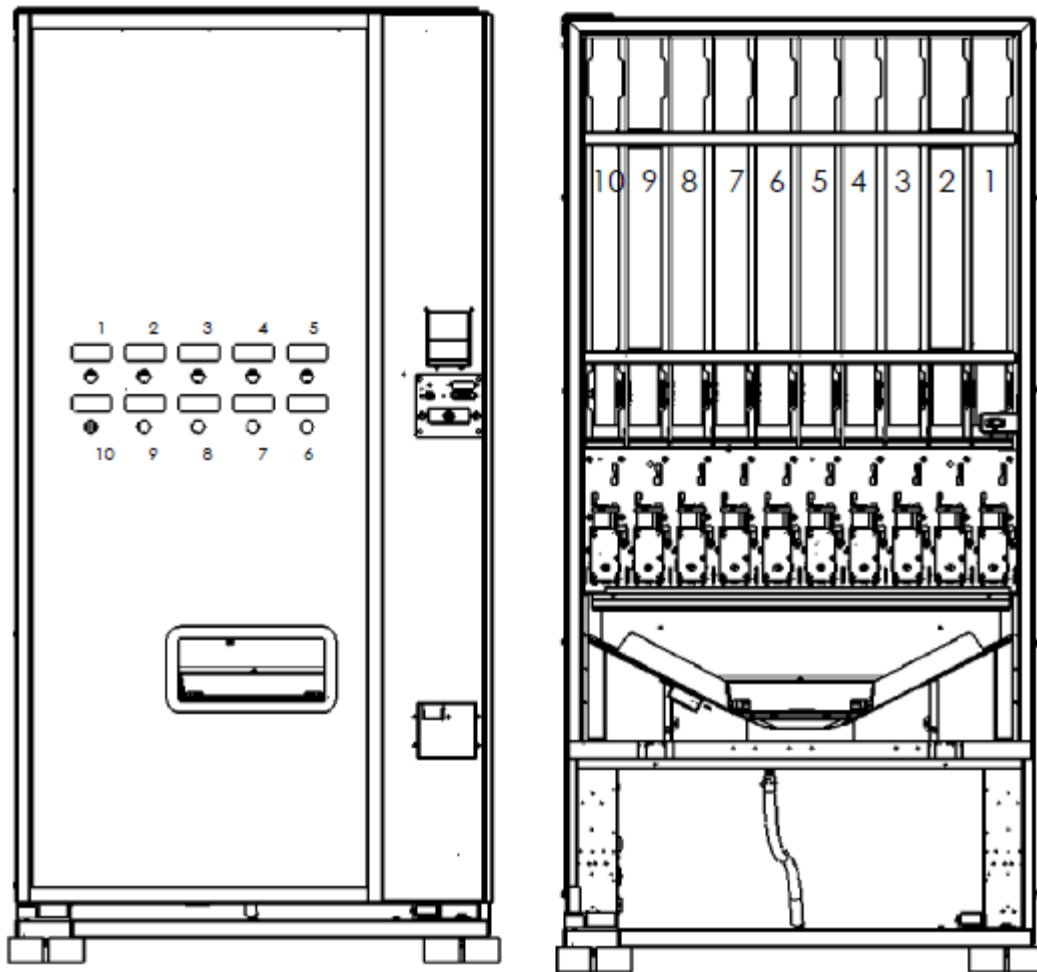

DNCB 640-10 (shown)	
Selection #	Column #
1	1
2	2
3	3
4	4
5	5
6	6
7	7
8	8
9	9
10	10

DNCB 640-9 (not shown)	
Selection #	Column #
1	1
1	2
2	3
3	4
4	5
5	6
6	7
7	8
8	9
9	10

DNCB 448-7 (not shown)	
Selection #	Column #
1	1
2	2
3	3
4	4
5	5
6	6
7	7

Setting The Vender Type

To program with “**Enter Number of Columns in Machine**” on the display press select button 1. The display will show “**6**” for six columns. Press select buttons 1 & 2 to scroll through available number of columns in the machine. When the displayed number of columns matches the number of columns in the machine, press select button 1 to set the number of columns. “**Set Model Number**” will appear on the display, press select button 1. The display will show the first available model number for the current vender type. Press select button 1 & 2 to scroll through the available vender model numbers for this vender. When the vender type you wish to save is showing on the display, press select button 1. The display will scroll “**1 = Set Package Type 2 = Exit**”. Press select button 1 and the display will show “**1**” indicating the package type. This will allow you to set the package type of the machine if it is different that the default of package type 2. Press select button 1 & 2 to scroll through the available package types. Press select button 1 to set the displayed package type. “**2=Exit 1=Prime Col 1**” will appear on the display. Press button 1 to prime column 1 or select button 2 to skip priming column 1. The display will then display “**2=Exit 1=Prime Col 2**”. Repeat the priming process until all columns have been primed or skipped.

6 column machines

DN552-5,
DN552-6,
DN552-7,
DN756-10DP

7 column machines

DN504-6,
DN504-7,
DN504-8,
DN532-5,
DN532-6,
DN532-7,
DN448-6
DN448-7

8 column machines

DN756-7,
DN756-8,
DN756-9,
DN756-10,
DN756-11,
DN756-12,
DN756-13,
DN756HV-12,

10 column machines

DN640-8, DN640-10, DN640-9
DN640HVV-11, DN640HVV-12
DN720-8, DN720-9, DN720-10,

DN720-12,
DN760-9,
DN760-10,
DN760-11, DN760HV-11
DN760-12, DN760HV-12
DN760-13,
DN770-12, DN770HV-11, DN770HV-12

The following are other model numbers that may appear:

6 column machines

DN552-5,
DN552-6,
DN552-7,
DN552-8,

7 column machines (continued)

DN532-5,
DN532-6,
DN532-7,
DN532-8,

8 column machines

DN756-7,
DN756-8,
DN756-9,
DN756-10,
DN756-11, DN756HV-11
DN756-12, DN756HV-12
DN756-13

10 column machines

DN760-9,
DN760-10,
DN760-11,
DN760-12,
DN760-13

The most important facets of proper vender care and maintenance are the electrical power supplied to it, leveling, and cleanliness of the machine and its components.

POWER

The vender must be connected to a dedicated 120VAC, 15 Amp circuit (U.S. and Canada).

CAUTION:

REMOVE POWER TO THE VENDER PRIOR TO CONNECTING / DISCONNECTING ANY ELECTRICAL COMPONENTS FOR TESTING OR REPLACEMENT.

Periodically inspect the power supply cord for damage. If the cord or plug is worn or damaged, it must be replaced with a power supply cord of the same type, size and specification as originally provided with the machine.

DO NOT USE THE VENDING MACHINE UNTIL THE WORN OR DAMAGED CORD IS REPLACED.

The Ground Fault Circuit Interrupter (GFCI) must be tested frequently and before each use in accordance with the instructions provided on the GFCI device.

IF THE GFCI DOES NOT PASS THE TEST, DO NOT USE THE MACHINE.

Unplug the supply cord from the receptacle and call the Crane Merchandising Systems Technical Support Group for assistance at 1-803-266-5001.

CLEANING



DO NOT USE A WATER JET OR NOZZLE TO CLEAN THE VENDER

SIGN FACE

The polycarbonate sign face requires proper cleaning to prolong its service life. Periodically clean the sign as follows:

Rinse the sign with a soft cloth or sponge soaked in warm water. If necessary, use a mild soap to loosen any dirt or grime. DO NOT SCRUB or use a brush or squeegee. Scrubbing may cause damage to signs with a clear ultraviolet resistant coating (prevents yellowing). Repeat the above steps as necessary. To prevent spotting, dry the sign using a soft cloth.

CABINET

Wash the cabinet with a good detergent or soap mixed with warm water. Wax the vender often with a good grade of automobile wax. Any corrosion inside of the vender should be removed with a fine steel wool and the area should be painted with aluminum paint. Repair any scratches on painted surfaces to prevent corrosion.

DRAIN PAN, DRAIN TUBE, AND DRAIN HOSE

To prevent mold and mildew growth, and to avoid personal injury or property damage, the drain pan, drain tube, and drain hose must be properly aligned and routed. Ensure nothing obstructs the drain tube or drain hose and that the hose is not bent, pinched, or twisted in such a way as to prevent the flow of condensate. Periodically inspect the drain pan, drain tube, and drain hose for alignment and the presence of dirt, debris, mold, and mildew. Clean as needed.



THE COMPRESSOR ELECTRICAL CIRCUIT IS ALWAYS LIVE WHEN THE PLUG IS CONNECTED TO AN ELECTRICAL OUTLET

REFRIGERATION CONDENSER

Check the condenser periodically for dirt or lint build-up. Remove build-up with a brush or vacuum, or blow the dirt out of the condenser with compressed air and an approved safety nozzle. Ensure nothing obstructs the air intake at the bottom of the main door. Ensure nothing obstructs the air exhaust at the rear of the cabinet.

COIN ACCEPTOR

- Follow the coin acceptor manufacturer's cleaning instructions.

LUBRICATING THE VENDER

Time	Component	Lubricant Example
Every 6 months (or as needed)	Main Door 1. Lock Bolt & Nut Retainer	Mechanics Friend
	2. Hinge Pivot Points	Mechanics Friend
Every Year (or as needed)	Inner Door 1. Hinge Pivot Points	Mechanics Friend
	Inner Door 1. Door Gasket	Petroleum Jelly

MEMORY RESET

To reset memory enter the AUTO "Auto Test" menu and scroll to the option to reset the memory. Press select button 1 to select this option and follow the displayed prompts. Once the machine has cleared its memory it will be ready to program.

EPROM REPLACEMENT

Software changes / upgrades are accomplished by changing the EPROM on the Control Board.

Generic DNCB640/448 Single Board Controller Software Update Procedure

This document describes how to update software on the Single Board Controller (SBC). **Note:** All existing software revisions automatically update the new software revision upon power up. Manual reprogramming is also available to update the software.

Important: EPROM containing software is sensitive to Electrostatic Discharge (ESD). Failure to handle the EPROM carefully could cause damage, which may result in a failed Single Board Controller (SBC).

ALWAYS KEEP THE EPROM IN THE ESD TUBE. GROUND YOURSELF ON THE VENDER CABINET BEFORE REMOVING THE EPROM FROM THE ESD TUBE OR CONTROL BOARD. AN EPROM CAN BE USED TO PROGRAM MANY VENDERS, AS LONG AS CARE IS TAKEN NOT TO DAMAGE THE EPROMS LEGS.

ALWAYS TURN POWER OFF BEFORE REMOVING OR INSTALLING EPROMS IN THE CONTROL BOARD.

Note: Use the SBC programming manual to program a vender that has a Single Board Controller (SBC) installed.

I. EPROM removal

- Power down the Vender. **Ground yourself on the vender cabinet before removing the EPROM from the ESD tube or control board.**
- If the EPROM is present in the SBC, remove the existing EPROM from the SBC.
 - Note: An EPROM does not need to be in the board after the SBC has been programmed. The EPROM can be used to reprogram other boards.
- Verify the pins of the new EPROM are not bent before installing in the EPROM socket.
- Install the new EPROM in the EPROM socket. Ensure the EPROM is oriented correctly with its reference marker (locator) in the same direction as the reference marker (locator) of the EPROM socket. Do not rely on the EPROM label for orientating the EPROM. See Figure 1.

II. Automatic Reprogramming (all software revisions)

- Turn power on to Vender. When auto-updating, the display will remain blank while the red LED on the board blinks rapidly for 3-4 seconds. Verify the new software version is shown on the display. If the new software version (the software version of the newly installed EPROM) displays, the SBC software has been successfully updated. If not, verify the EPROM is seated properly, with the reference marker oriented correctly and follow instructions for manual update if updating from 804,920,871.11. If problems still exist, contact the Crane Merchandising Systems Technical Service Department.

Note: To remove the EPROM after programming is complete turn power off, **ground yourself on the vender cabinet before removing the EPROM**, remove the EPROM, turn power on, test vender for proper operation.

III. Manual Reprogramming (if an EPROM does not automatically reprogram the SBC)

- At power up, the current software version will be displayed. To manually program the control board with the new software, press the blue service switch on the SBC to enter the service menu. Advance to "**Auto Test**" menu by holding buttons 1 & 2 simultaneously. Enter Auto Test by pressing button 1, and advance to the "**Reprogramming Microprocessor**" submenu by holding buttons 1 & 2 simultaneously.
- At the "**Reprogramming Microprocessor**" prompt, press button 1. "**THIS OPERATION REPROGRAMS VENDOR**" shows on the display. Press button 1 at this prompt. Next display will show "**BUTTON 2 = REPROGRAM, BUTTON 3 = EXIT**".

- Press button 2 to reprogram vender with the new software. **“Reprogramming Vendor...”** displays while the red LED on the board blinks rapidly for 3-4 seconds. Verify the new software version, and previous settings return to the display. If the new software version (the software version of the newly installed EPROM) shows on the display, the SBC software has been successfully updated.

Note: To remove the EPROM after programming is complete, remove power to the vender, **ground yourself on the vender cabinet before removing the EPROM**, remove the EPROM, while still grounded install a label on the microprocessor showing the revision of software that is installed in the SBC, power the vender back on and test for proper operation.

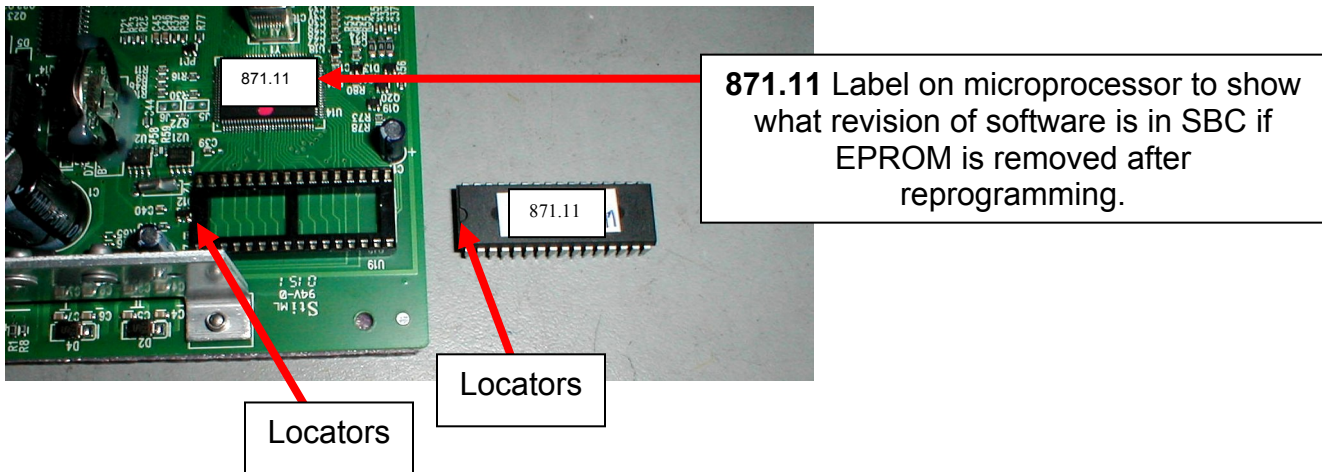
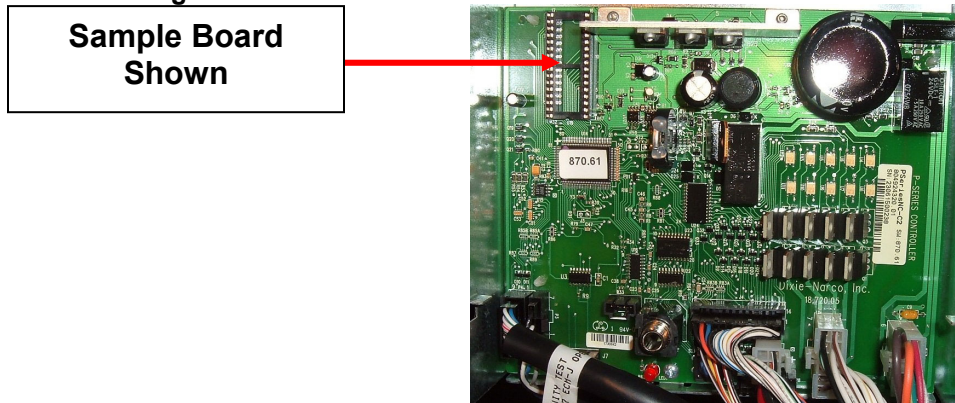
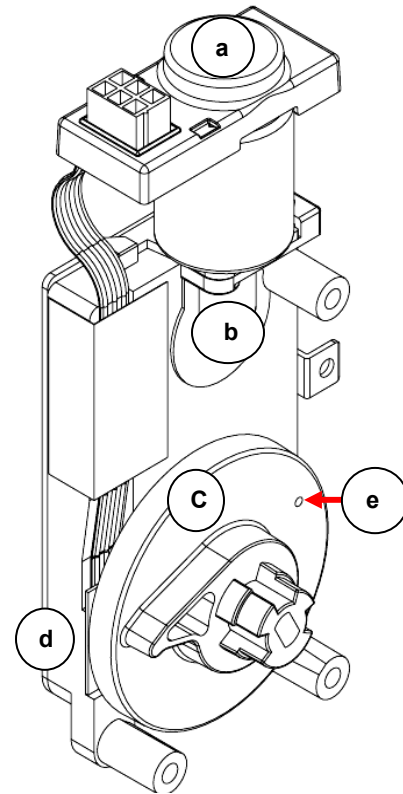

Figure 1 – EPROM REPLACEMENT



REFRIGERATION

	DOMESTIC	220 VAC
Compressor	Embraco, 1/3 HP, FFU130HAX Unit uses 9.0 oz. of 134a Refrigerant	NEK6212Z 220/50 1/3 Embraco Unit uses 7.5 oz. of 134a Refrigerant
Start Relay	115 VAC,	EMBRACO #9660041155
Start Capacitor	115 VAC	77-88mfd/330v EMBRACO
Thermal Overload	115 VAC	TO741/G9 EMBRACO
Condenser Fan	9W Motor 115 V/60HZ FV900CW30S.	9W Motor CW MORRILL SPD9HUB2
Evaporator Fan	TBD.	EMBRACO 1900RPM 230/50



VEND MOTOR OPERATION

The Control Board is responsible for the operation of the Vend Motor Assembly. It supplies 24VDC to the Vend Motors through the P1 Connector of the Control Board and monitors its movement from the Encoder through the J4 Connector.

The Vend Motor Assembly consists of an Encoder (a), Motor and Gearbox (b), Cam Assembly (c) and a Home Sensor (d).

The Encoder sends counts to the Control Board to advise it of its position.

The Cam Assembly includes a Magnet (e) which actuates the Home Sensor when Vend Motor returns to the Home Position.

The Home Position is the starting position of each rotation of the Vend Motor. When the Main Door is closed, the Control Board identifies columns which are deemed as **SOLD OUT** or jammed. The Display will read “**PRIME**” and runs the Vend Motor to the Home Position. The Rotor is reloaded in this process.

When a selection is activated, the Control Board sends 24VDC to the Vend Motor. In turn the Encoder sends pulses to the Control Board which stops the Vend Motor at a predetermined point or **Vend Angle** in programming.

Service Only

SBC Control Board

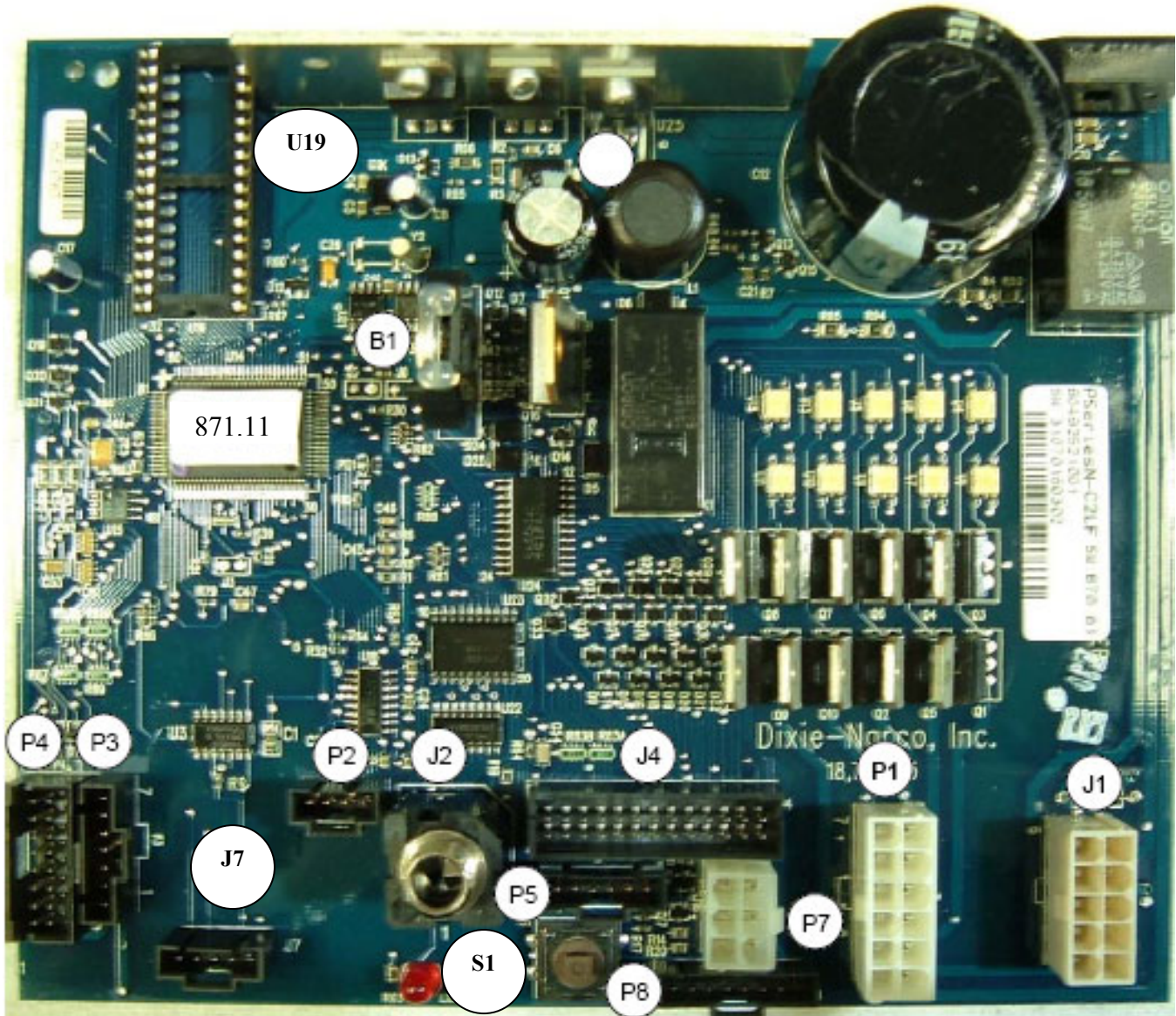

Position	Description	Position	Description
P1	Motor	P8	Energy Management
P2	Secondary DEX	J1	AC Power
P3	Display	J2	DEX
P4	Select Switches	J4	Home Switch
P5	Temp Sensor	J7	Optional
P7	MDB	B1	Battery
U19	EPROM Socket	S1	Service Switch

The following charts are intended to isolate and correct most problems you might encounter.

ALL COINS ARE REJECTED

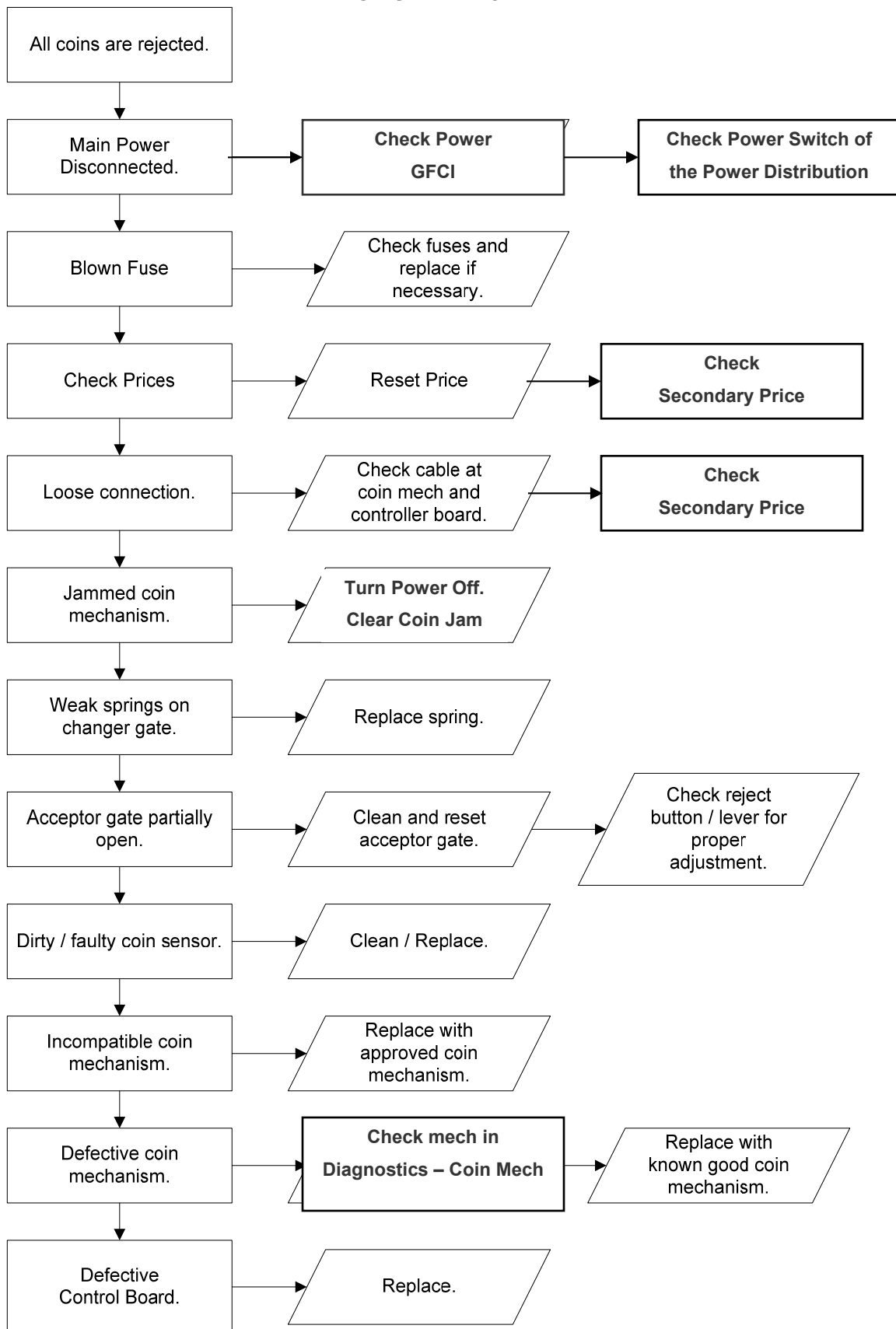

ALL BILLS ARE REJECTED

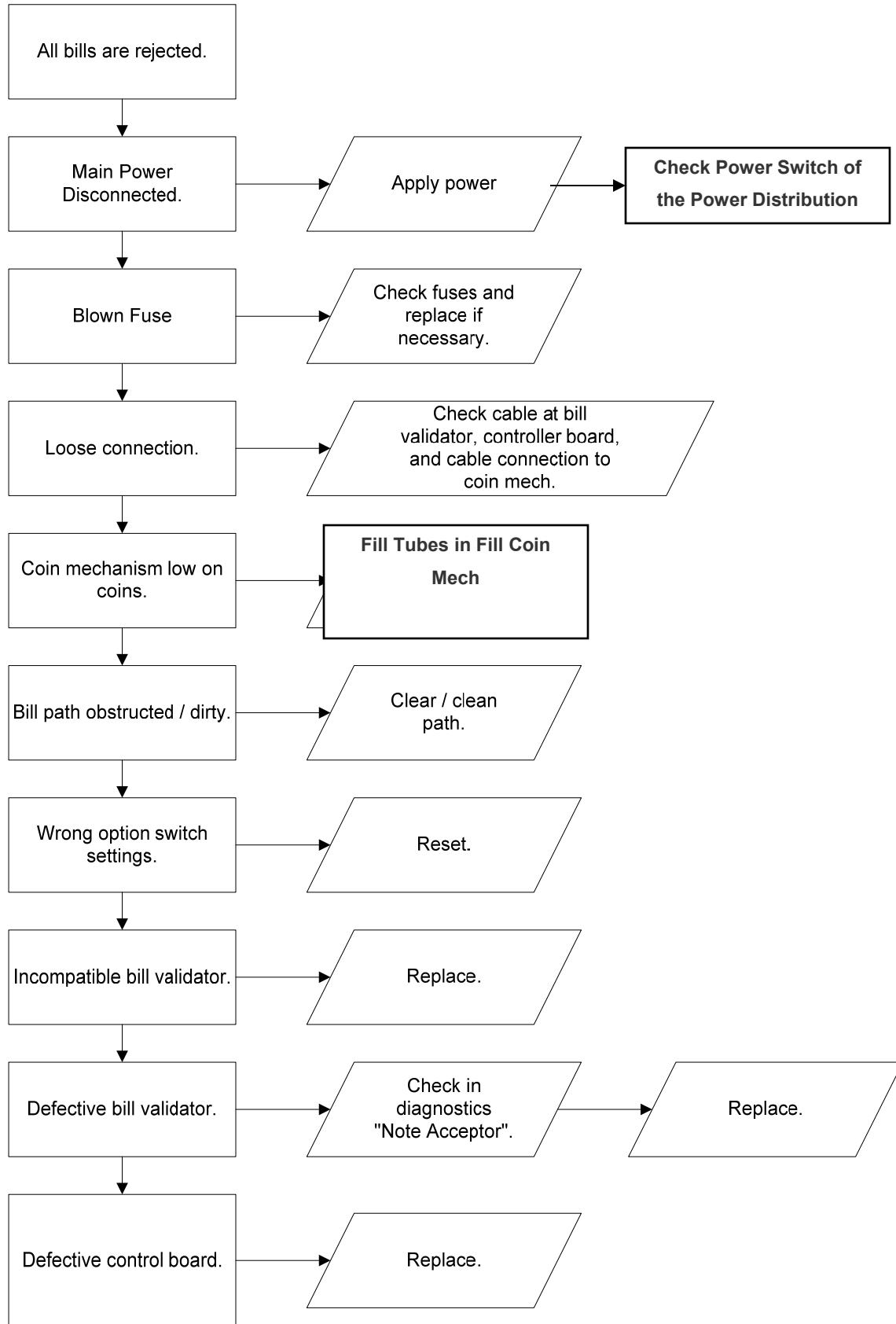

INCORRECT CHANGE DISPENSED

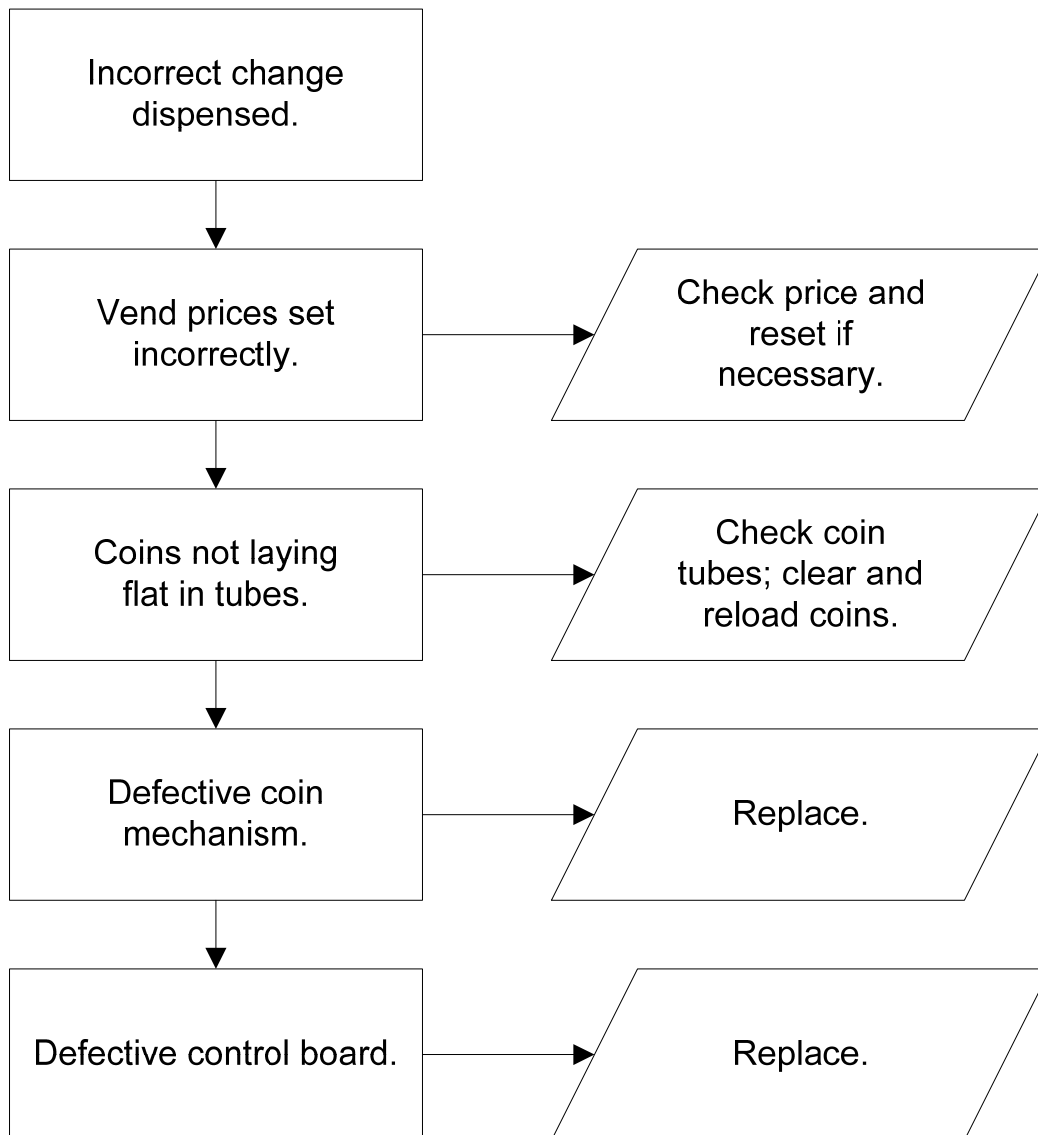

SELECTION WILL NOT VEND

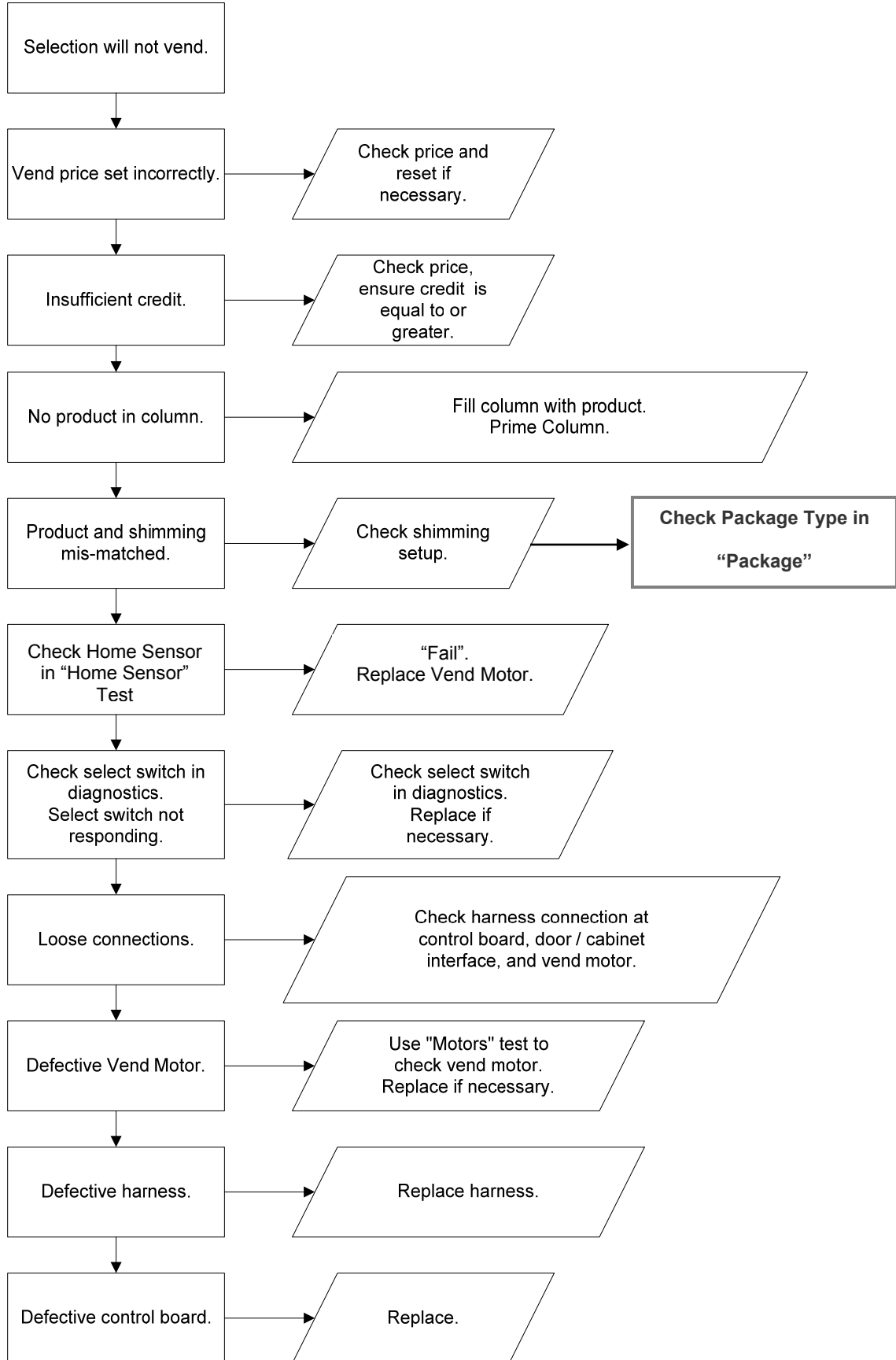

ICE / FROST ON EVAPORATOR

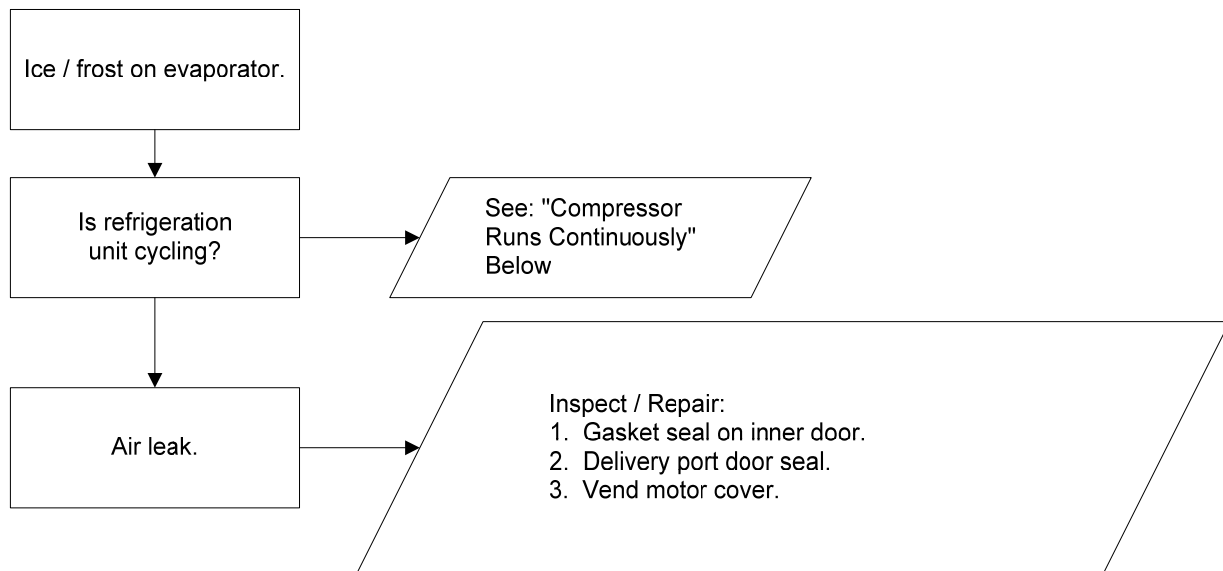

COMPRESSOR RUNS CONTINUOUSLY

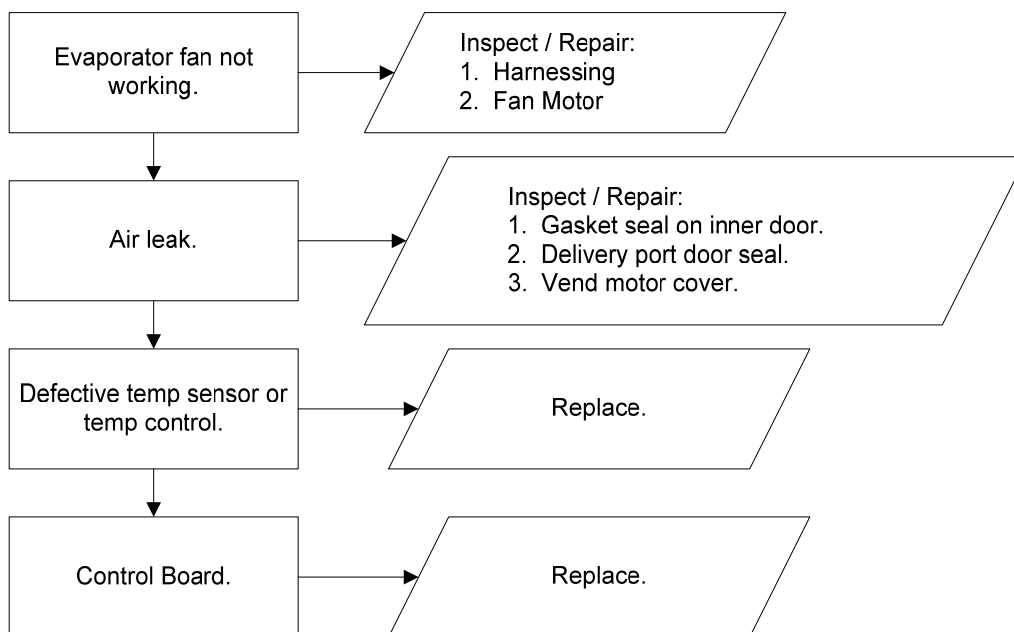

COMPRESSOR WILL NOT START

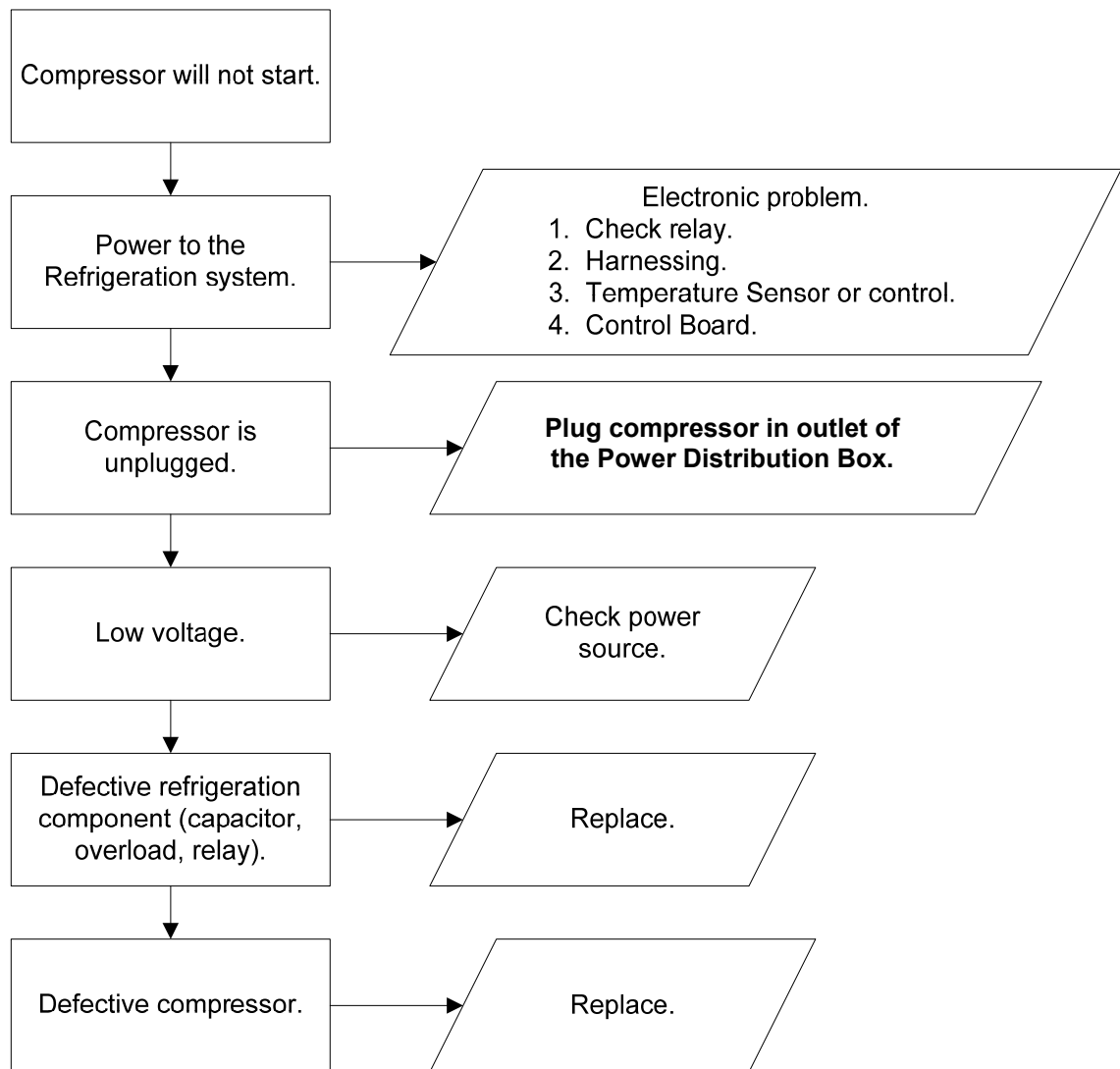

Troubleshooting Tip: Use a short 15 Amp extension cord and plug the compressor directly into the wall outlet. This will bypass the Electronic Controls.
Note: For Testing Purposes Only.

MACHINE NOT COOLING

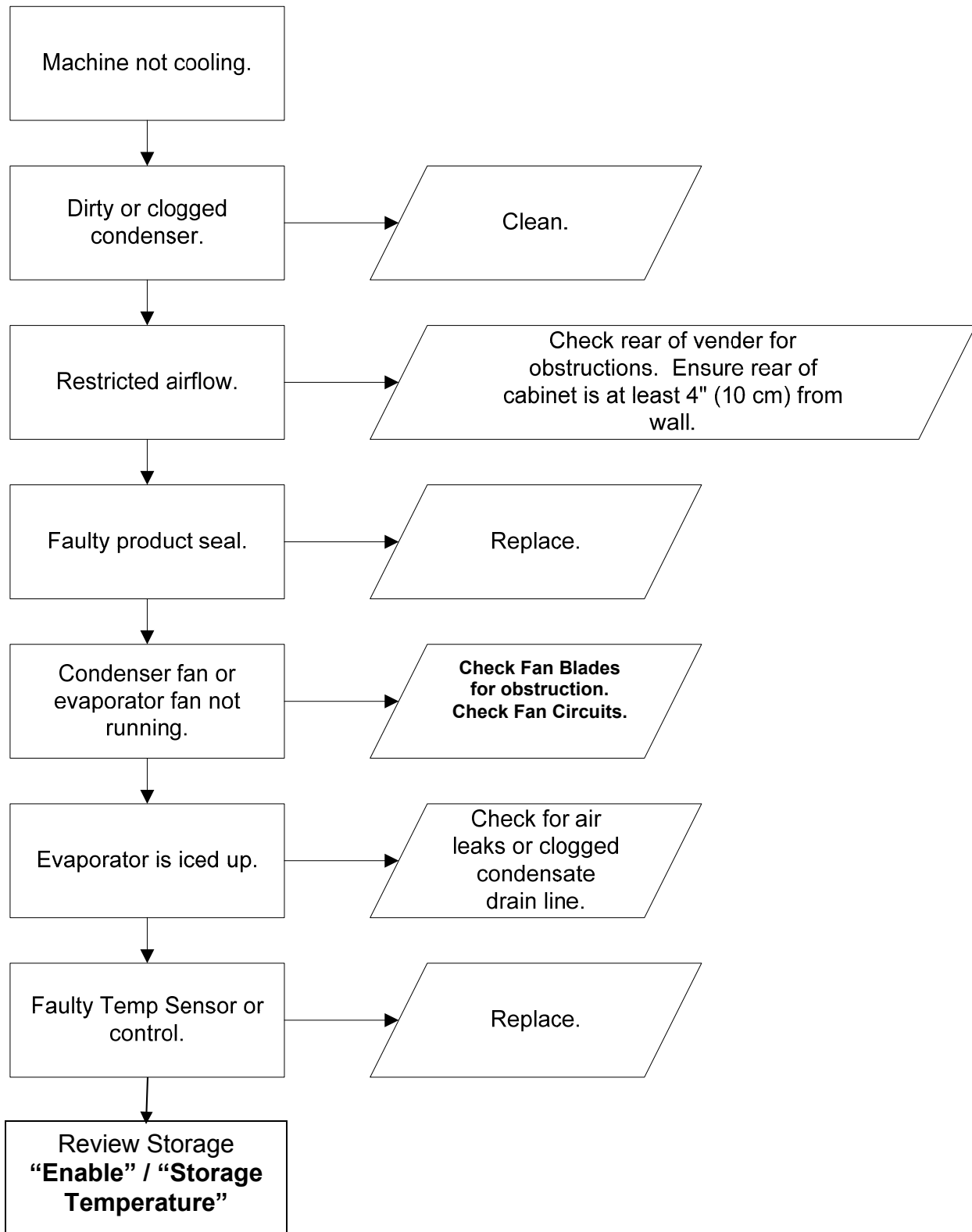

CANNOT ENTER THE MENU OR DIAGNOSTICS



Note: Prior to checking wires or connections, ensure power has been removed from vender.

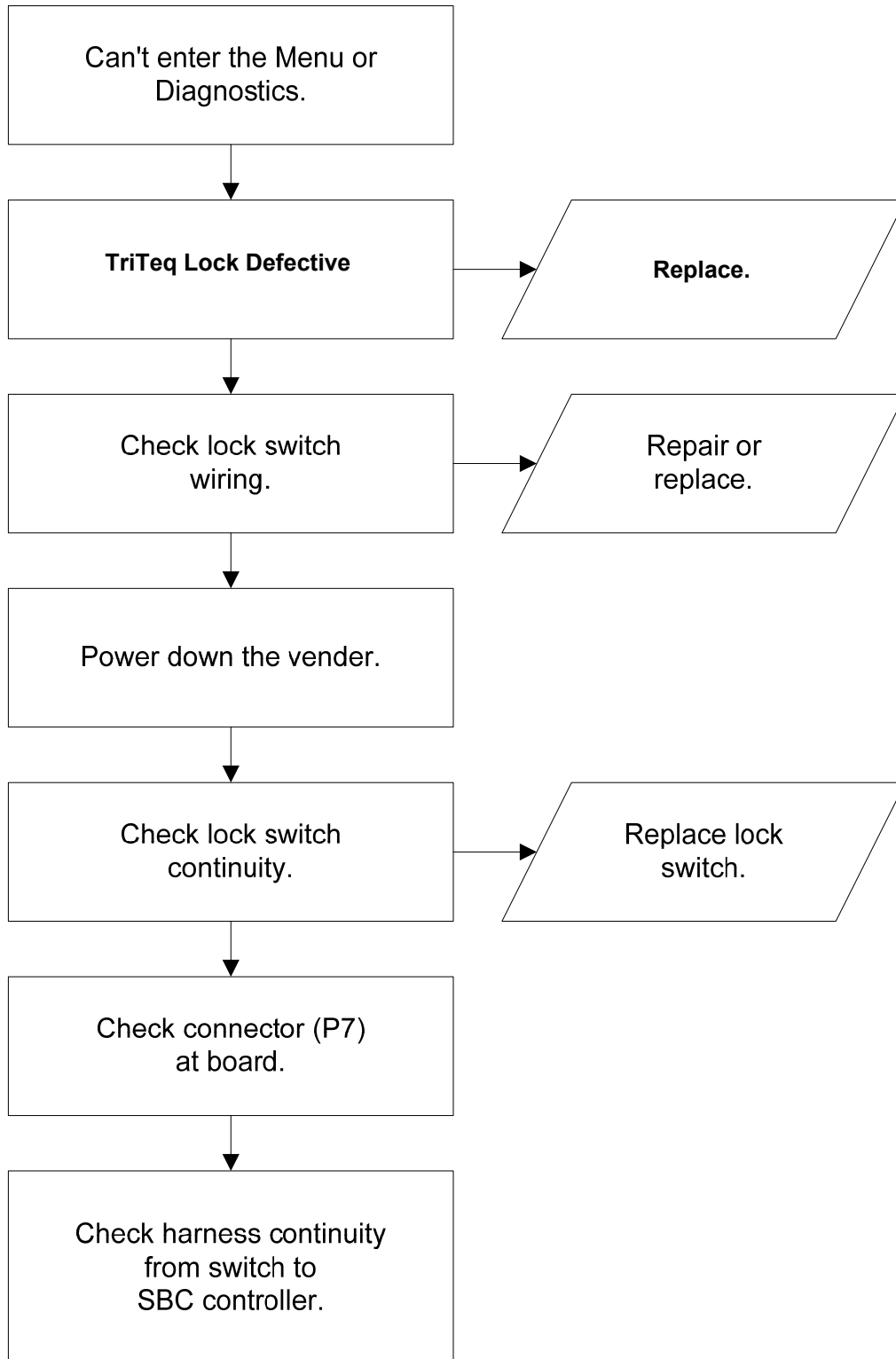

LIGHTS ARE NOT ON

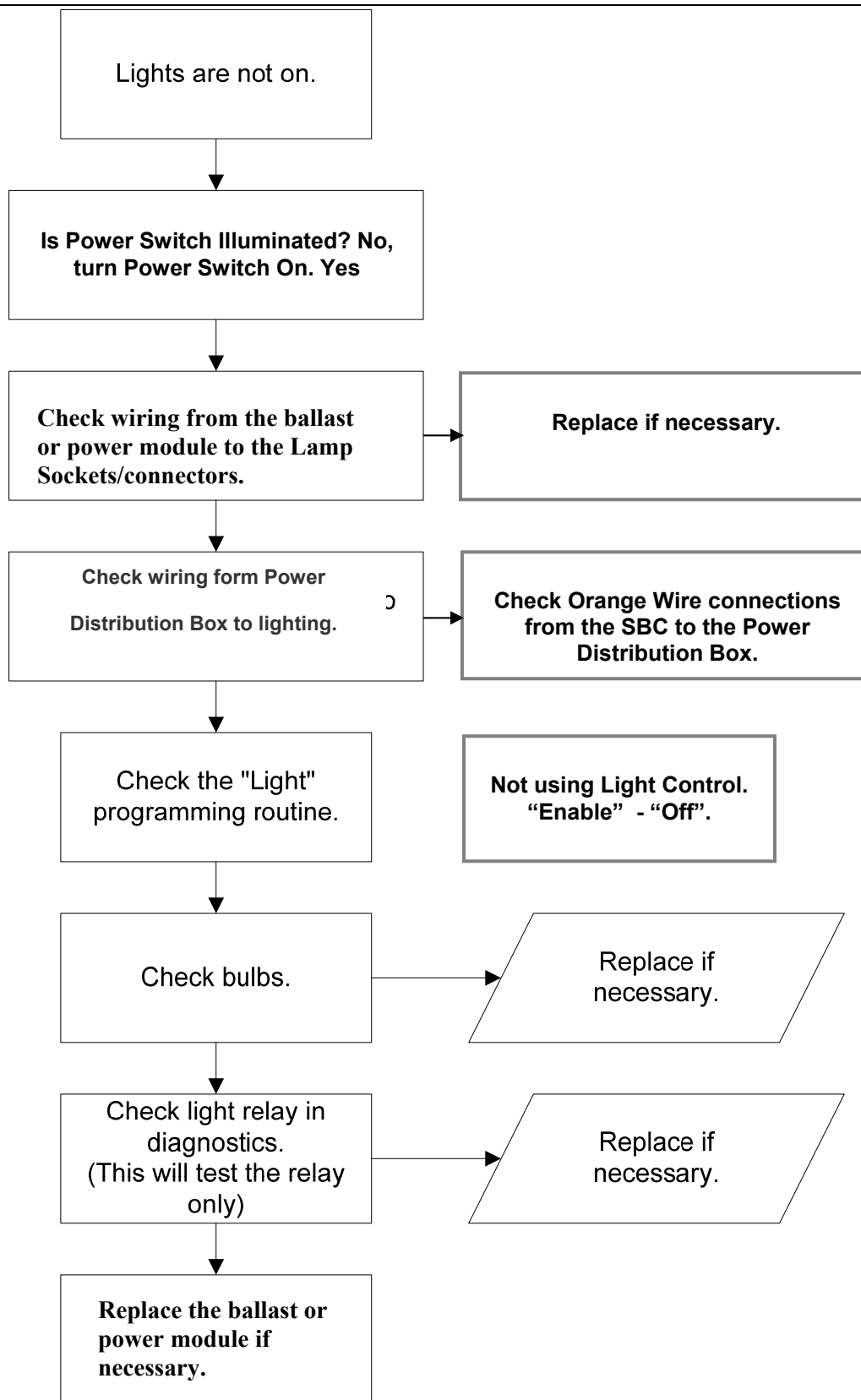

**ONE OR MORE MOTORS RUN WHEN MAIN DOOR IS CLOSED
(Display Scrolls "PRIMING")**

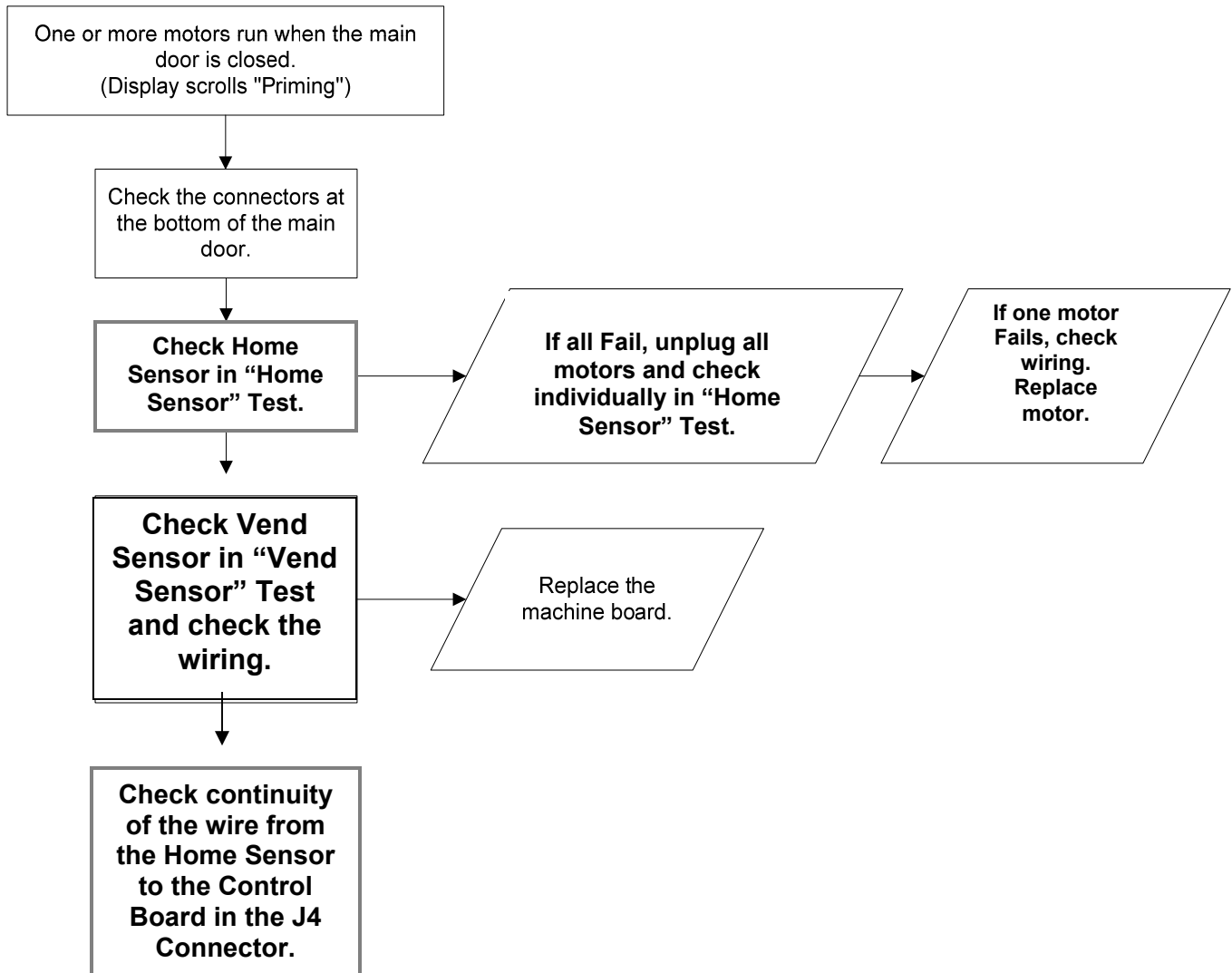

SOLD OUT

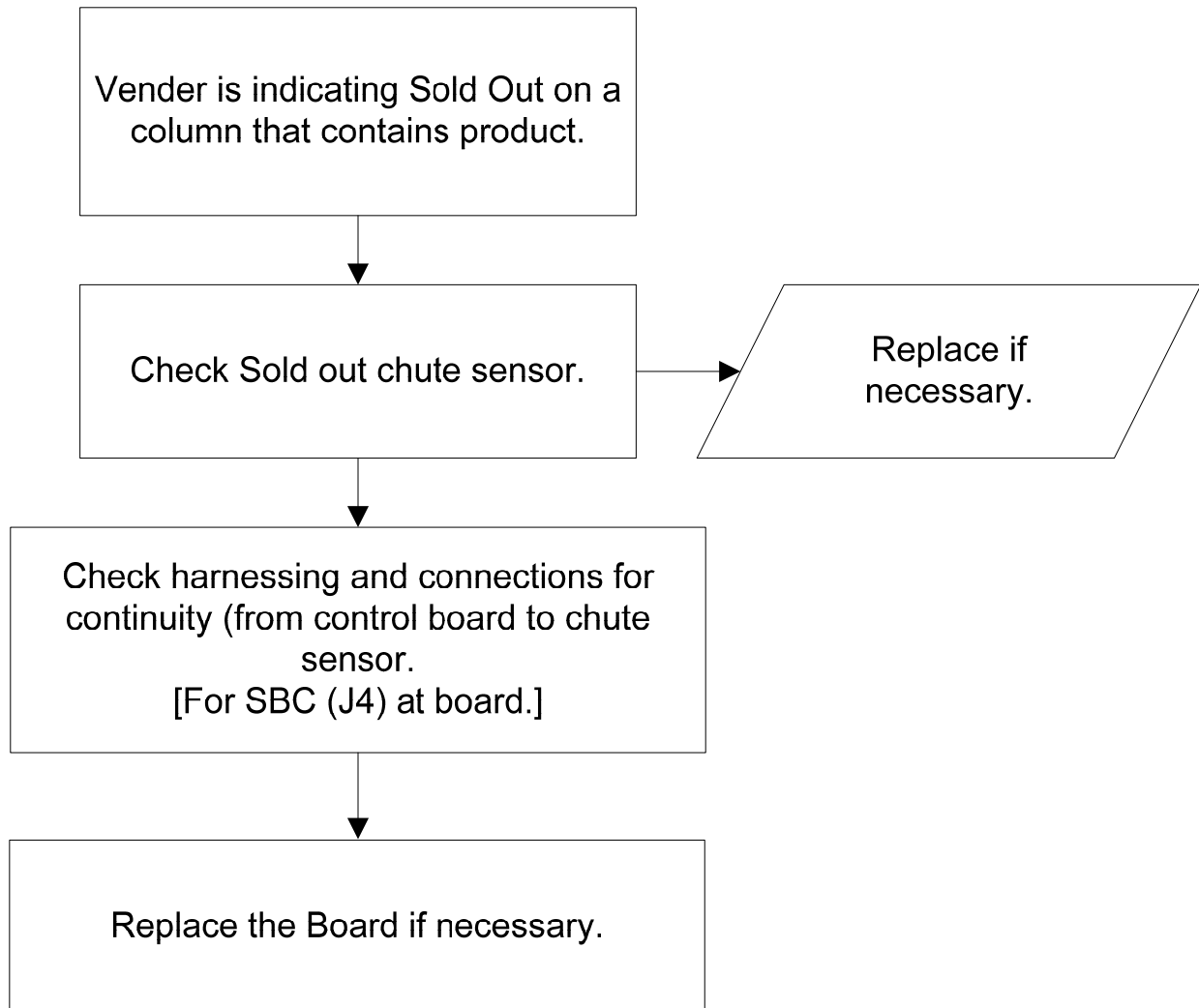

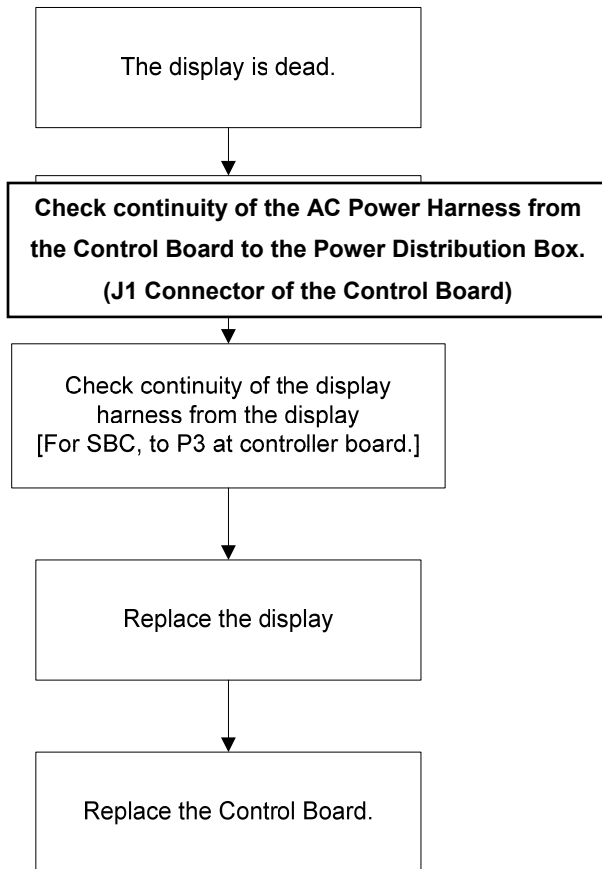
THE DISPLAY IS DEAD

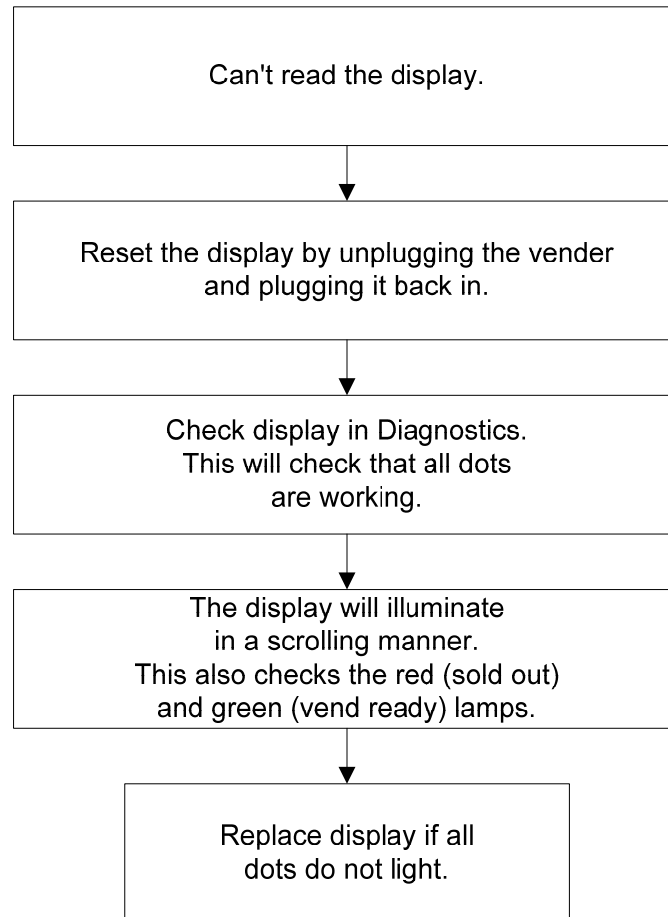
CAN'T READ THE DISPLAY

10 Select / 10 Column – Domestic DNCB640 (80389200)

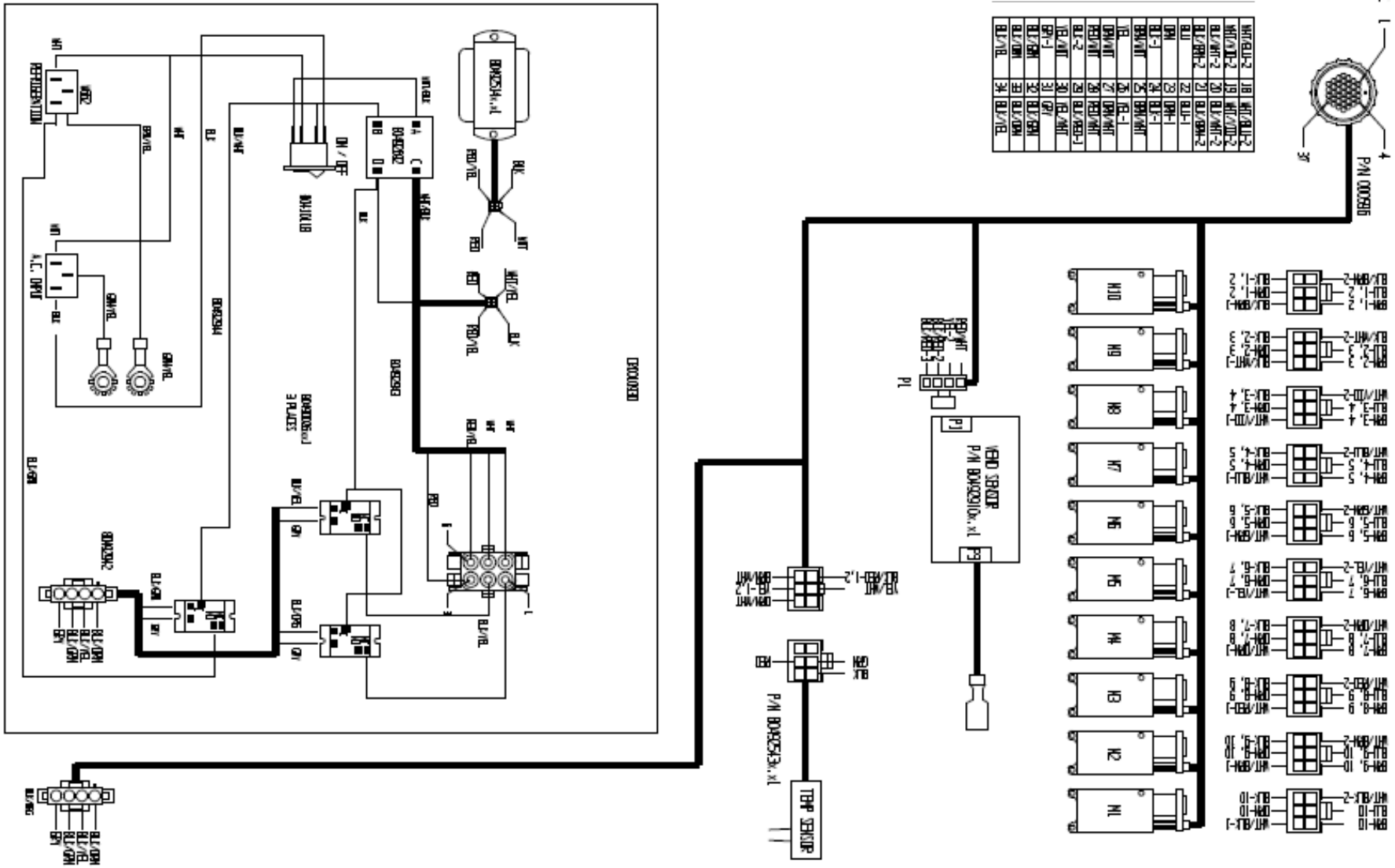

10 Select / 10 Column – Export DNCB640 (TBD)

7 Select / 7 Column – Domestic DNCB448 (80389202)

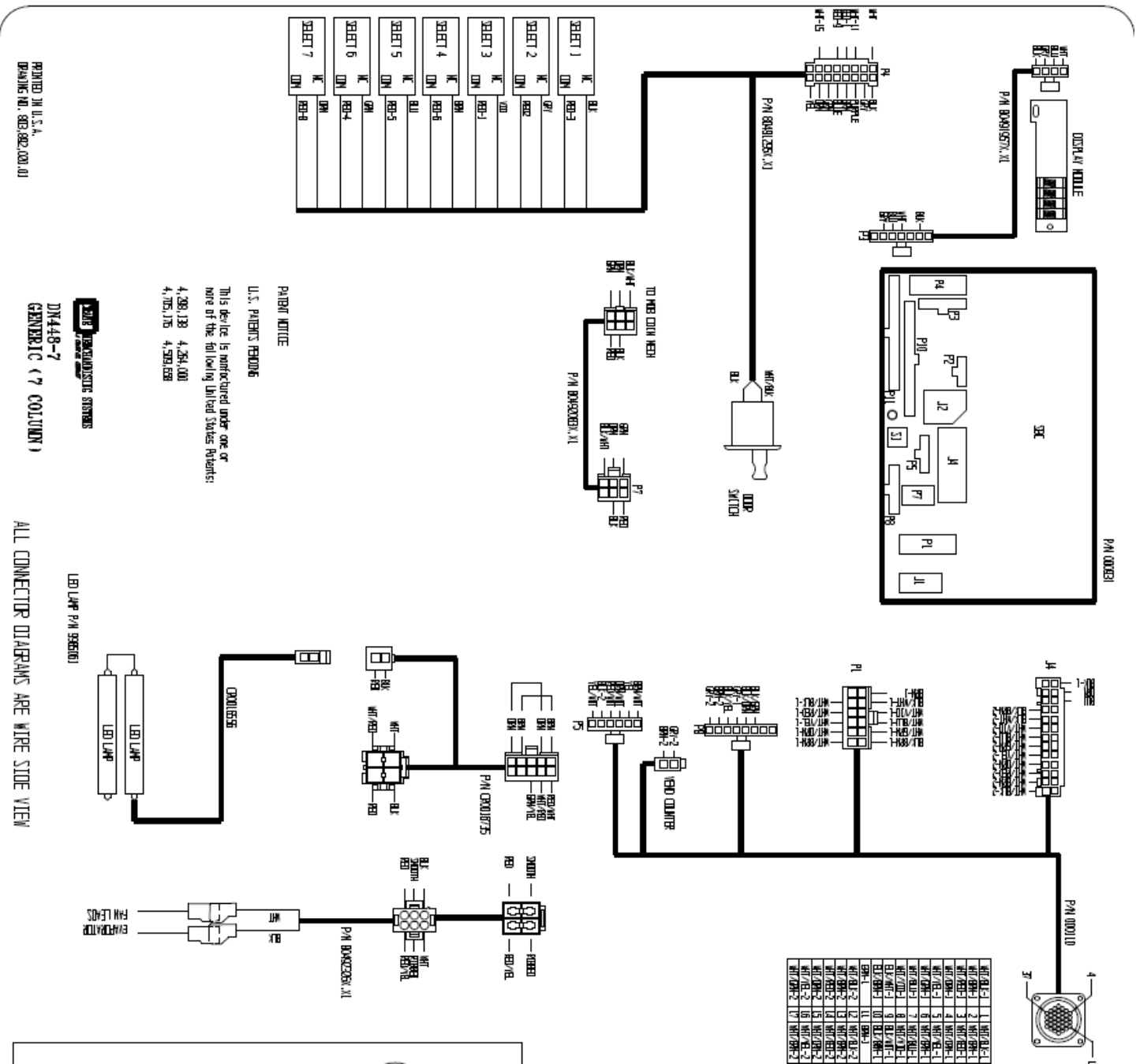

PRINTED IN U.S.A.
DRAWING NO. 803892.003.00

80
32
65
70
-

PATENT NOTICE
U.S. PATENT PENDING
This device is manufactured under one or more of the following United States Patents:
4,286,138 4,284,000
4,705,176 4,599,688

SALES REPRESENTATIVE SERVICES
DNCB448-7
GENERIC (7 COLUMN)

ALL CONNECTOR DIAGRAMS ARE WIRE SIDE VIEW

Service Only

7 Select / 7 Column – Domestic DNCB448 (80389202)

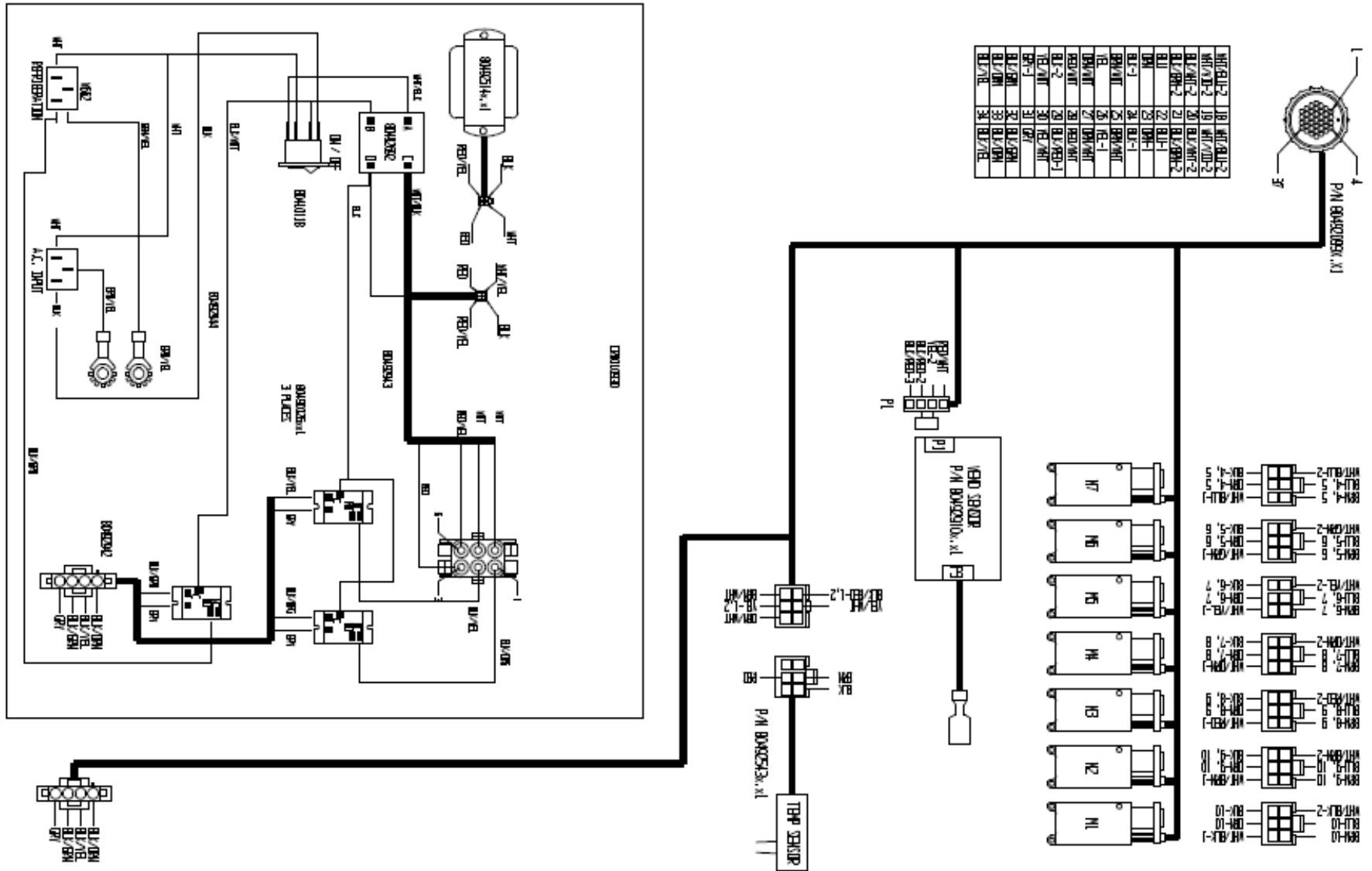

7 Select / 7 Column – Export DNCB448 (TBD)

Refrigeration Circuit Diagrams

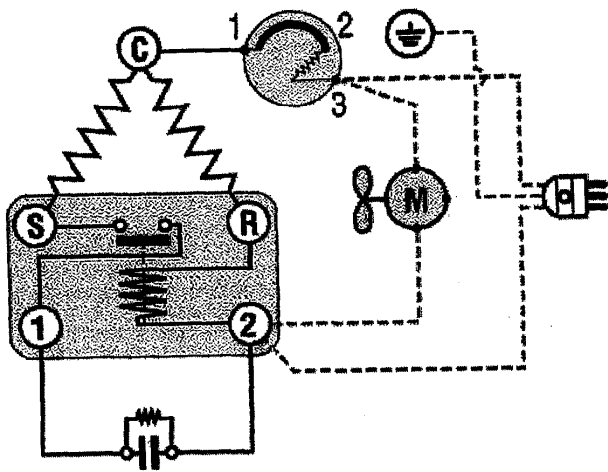

Symbol	Description
	Current Start Relay with Capacitor Connections
	Start Capacitor
	Overload Protector
	Fan
	Single Phase Motor
	Earth Connection
	Single Phase Supply
	Common
	Run
	Start
	Factory Made Connections
	Connections to be made

Refrigeration Circuit